



**PEPERIKSAAN PERCUBAAN  
SIJIL PELAJARAN MALAYSIA 2021**

Logo  
sekolah

**MATEMATIK**  
Kertas 1  
1 jam 30 minit

Nama Sekolah

**1449/1**

Satu jam tiga puluh minit

---

**JANGAN BUKA KERTAS SOALAN INI SEHINGGA DIBERITAHU**

1. Kertas peperiksaan ini adalah dalam dwibahasa.

*This examination paper is bilingual.*

2. Soalan dalam Bahasa Melayu mendahului soalan yang sepadan dalam Bahasa Inggeris.

*Questions in Malay precede the corresponding questions in English.*

3. Calon dikehendaki membaca maklumat di halaman belakang kertas peperiksaan ini.

*Candidates are required to read the information on the back page of this examination paper.*

Kertas halaman ini mengandungi **26** halaman bercetak

---

**RUMUS MATEMATIK**  
**MATHEMATICAL FORMULAE**

Rumus-rumus berikut boleh membantu anda untuk menjawab soalan. Simbol-simbol yang diberi adalah yang biasa digunakan.

*The following formulae may be helpful in answering the questions. The symbols given are the ones commonly used*

**NOMBOR DAN OPERASI**  
**NUMBERS AND OPERATIONS**

$$1 \quad a^m \times a^n = a^{m+n} \qquad 2 \quad a^m \div a^n = a^{m-n}$$

$$3 \quad (a^m)^n = a^{mn} \qquad 4 \quad a^{\frac{m}{n}} = (a^m)^{\frac{1}{n}}$$

$$5 \quad \text{Faedah mudah / Simple interest, } I = Prt$$

$$6 \quad \text{Nilai matang / Maturity value, } MV = P \left(1 + \frac{r}{n}\right)^{nt}$$

$$7 \quad \text{Jumlah bayaran balik / Total repayment, } A = P + Prt$$

**PERKAITAN**  
**RELATIONS**

$$1 \quad \text{Jarak / Distance} = \sqrt{(x_2 - x_1)^2 + (y_2 - y_1)^2}$$

$$2 \quad \text{Titik Tengah / midpoint}(x, y) = \left(\frac{x_1+x_2}{2}, \frac{y_1+y_2}{2}\right)$$

$$3 \quad \text{Purata laju} = \frac{\text{jarak yang dilalui}}{\text{masa yang diambil}}$$

$$\text{Average speed} = \frac{\text{distance travelled}}{\text{time taken}}$$

$$4 \quad m = \frac{y_2 - y_1}{x_2 - x_1}$$

$$5 \quad m = -\frac{\text{pintasan-y}}{\text{pintasan-x}}$$

$$m = -\frac{\text{y-intercept}}{\text{x-intercept}}$$

$$6 \quad A^{-1} = \frac{1}{ad - bc} \begin{pmatrix} d & -b \\ -c & a \end{pmatrix}$$

**SUKATAN DAN GEOMETRI**  
**MEASUREMENT AND GEOMETRY**

- 1 Teorem Pythagoras / *Pythagoras Theorem*  $c^2 = a^2 + b^2$
- 2 Hasil tambah sudut pedalaman poligon / *Sum of interior angles of a polygon*  
 $= (n - 2) \times 180^\circ$
- 3 Lilitan bulatan =  $\pi d = 2\pi j$   
*Circumference of circle* =  $\pi d = 2\pi r$
- 4 Luas bulatan =  $\pi j^2$   
*Area of circle* =  $\pi r^2$
- 5 
$$\frac{\text{Panjang lengkok}}{2\pi j} = \frac{\theta}{360^\circ}$$
$$\frac{\text{Arc length}}{2\pi r} = \frac{\theta}{360^\circ}$$
- 6 
$$\frac{\text{Luas sektor}}{\pi j^2} = \frac{\theta}{360^\circ}$$
$$\frac{\text{Area of sector}}{\pi r^2} = \frac{\theta}{360^\circ}$$
- 7 Luas layang =  $\frac{1}{2} \times$  hasil darab panjang dua pepenjuru  
*Area of kite* =  $\frac{1}{2} \times$  *product of two diagonals*
- 8 Luas trapezium =  $\frac{1}{2} \times$  hasil tambah dua sisi selari  $\times$  tinggi  
*Area of trapezium* =  $\frac{1}{2} \times$  *sum of parallel sides*  $\times$  *height*
- 9 Luas permukaan silinder =  $2\pi j^2 + 2\pi jt$   
*Surface area of cylinder* =  $2\pi r^2 + 2\pi rh$
- 10 Luas permukaan kon =  $\pi j^2 + \pi js$   
*Surface area of cone* =  $\pi r^2 + \pi rs$
- 11 Luas permukaan sfera =  $4\pi j^2$   
*Surface area of sphere* =  $4\pi r^2$
- 12 Isipadu prisma tegak = luas keratan rentas  $\times$  tinggi  
*Volume of right prism* = *cross sectional area*  $\times$  *height*
- 13 Isipadu silinder =  $\pi j^2 t$   
*Volume of cylinder* =  $\pi r^2 h$

- 14 Isipadu kon =  $\frac{1}{3}\pi j^2 t$   
*Volume of cone* =  $\frac{1}{3}\pi r^2 h$
- 15 Isipadu sfera =  $\frac{4}{3}\pi j^3$   
*Volume of sphere* =  $\frac{4}{3}\pi r^3$
- 16 Isipadu piramid tegak =  $\frac{1}{3} \times$  luastapak  $\times$  tinggi  
*Volume of right pyramid* =  $\frac{1}{3} \times$  base area  $\times$  height
- 17 Faktor skala,  $k = \frac{PA'}{PA}$   
 Scale factor,  $k = \frac{PA'}{PA}$
- 18 Luas imej =  $k^2 \times$  luas objek  
*Area of image* =  $k^2 \times$  area of object

**STATISTIK DAN KEBARANGKALIAN**  
**STATISTICS AND PROBABILITY**

- 1 Min / Mean,  $\bar{x} = \frac{\sum x}{N}$
- 2 Min / Mean,  $\bar{x} = \frac{\sum fx}{f}$
- 3 Varians / Variance,  $\sigma^2 = \frac{\sum(x - \bar{x})^2}{N} = \frac{\sum x^2}{N} - \bar{x}^2$
- 4 Varians / Variance,  $\sigma^2 = \frac{\sum f(x - \bar{x})^2}{f} = \frac{\sum fx^2}{f} - \bar{x}^2$
- 5 Sisihan piawai / Standard deviation,  $\sigma = \sqrt{\frac{\sum(x - \bar{x})^2}{N}} = \sqrt{\frac{\sum x^2}{N} - \bar{x}^2}$
- 6 Sisihan piawai / Standard deviation,  $\sigma = \sqrt{\frac{\sum f(x - \bar{x})^2}{f}} = \sqrt{\frac{\sum fx^2}{f} - \bar{x}^2}$
- 7  $P(A) = \frac{n(A)}{n(S)}$
- 8  $P(A') = 1 - P(A)$

Jawab **semua** soalan

*Answer all questions*

1. Ungkapkan  $9.03 \times 10^4$  sebagai satu nombor tunggal.

*Express  $9.03 \times 10^4$  as a single number.*

- A 9 030
- B 90 300
- C 903 000
- D 9 030 000

2. Ungkapkan 3987.3 dalam bentuk piawai.

*Express 3987.3 in standard form.*

- A  $3.9873 \times 10^2$
- B  $3.9873 \times 10^{-2}$
- C  $3.9873 \times 10^3$
- D  $3.9873 \times 10^{-3}$

3. Tukarkan  $145_8$  kepada asas 4.

*Convert  $145_8$  to base 4.*

- A  $1002_4$
- B  $1020_4$
- C  $1121_4$
- D  $1211_4$

4. Diberi  $2 \times 5^3 + 5^2 + 3(5) = k_5$ , cari nilai k.

*Given that  $2 \times 5^3 + 5^2 + 3(5) = k_5$ , find the value of k.*

- A  $290_5$
- B  $2100_5$
- C  $2130_5$
- D  $2150_5$

5. Rajah 2 menunjukkan PQR ialah tangen kepada bulatan dengan pusat O, pada titik Q.  
*Diagram 2 shows PQR is the tangent to the circle with centre O, at point Q.*

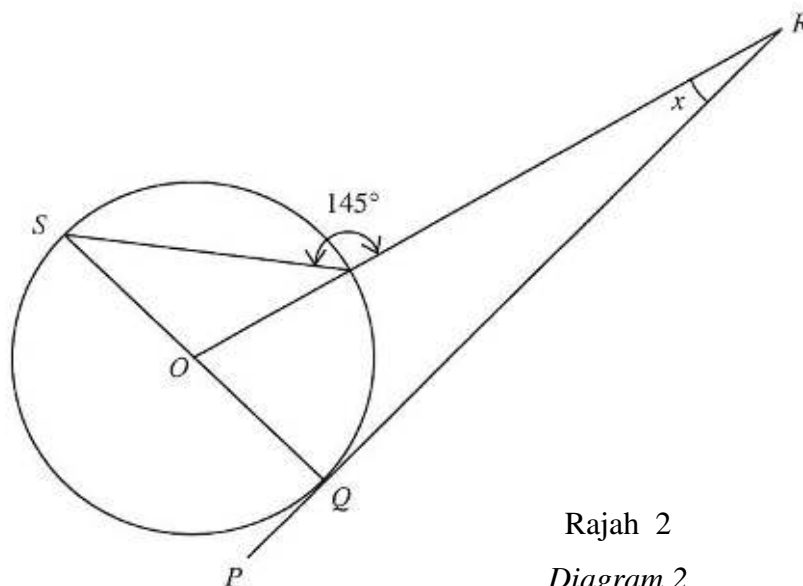

Rajah 2  
 Diagram 2

Cari nilai

*Find the value of  $x$ .*

- A  $20^\circ$   
 B  $35^\circ$   
 C  $40^\circ$   
 D  $55^\circ$
6. Pada bulan Februari 2020, Encik Patrick menerima jumlah pendapatan sebanyak RM4 500. Perbelanjaan tetap dan perbelanjaan tidak tetap bulanannya masing – masing ialah RM2 880 dan RM $x$ . Terdapat aliran tunai negatif sebanyak RM620. Hitung nilai  $x$ .  
*In February 2020, Mr Patrick received a total income of RM4 500. The monthly fixed expenses and non - fixed expenses are RM2 880 and RM $x$  respectively. There was a negative cash flow of RM620. Calculate the value of  $x$ .*
- A 1 000  
 B 2 240  
 C 3 500  
 D 3 880

7. Rajah 3 menunjukkan dua bulatan,  $Q$  dan  $R$ , dilukis pada grid segi empat sama.

$R$  adalah imej bagi  $Q$  di bawah suatu pembesaran berpusat  $K$

*Diagram 3 shows two circles,  $Q$  and  $R$ , drawn on square grids.  $R$  is the image of  $Q$  under an enlargement about the centre  $K$ .*

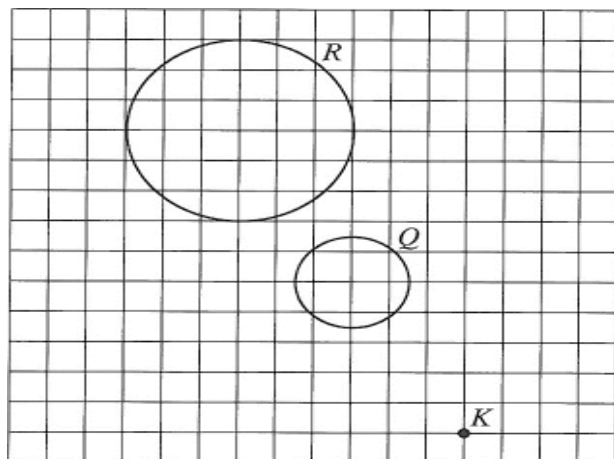

Rajah 3  
Diagram 3

Faktor skala pembesaran itu ialah

*The scale factor of the enlargement is*

- A -2
- B  $-\frac{1}{2}$
- C  $\frac{1}{2}$
- D 2
8.  $\frac{4}{x^2 - y^2} \div \frac{3x}{x + y} =$
- A  $\frac{12x}{x - y}$
- B  $\frac{12x}{x + y}$
- C  $\frac{4}{3x - y}$
- D  $\frac{4}{3x(x - y)}$

9. Rajah 4 menunjukkan dua buah segitiga,  $P$  dan  $Q$  yang dilukis pada satah cartes.

*Diagram 4 shows two triangle ,  $P$  and  $Q$  drawn on a cartesian plane.*

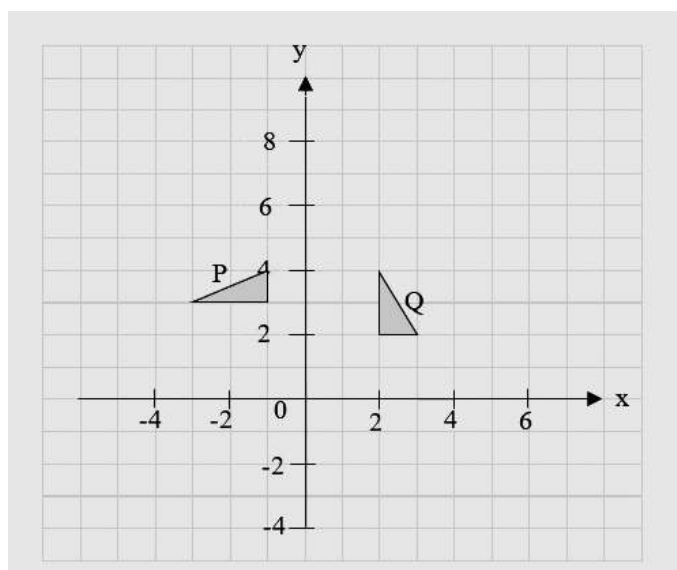

Rajah 4  
Diagram 4

$Q$  ialah imej bagi  $P$  dibawah putaran  $90^\circ$  ikut arah jam. Nyatakan koordinat pusat putaran tersebut

*$Q$  is the image of  $P$  under a rotation of  $90^\circ$ . State the coordinates of the center of rotation*

- A (0,1)  
B (1,0)  
C (1,4)  
D (4,1)
10. Carmen membeli  $p$  pembaris dengan harga 70 sen setiap satu dan  $q$  pensel dengan harga 60 sen setiap satu. Dia menjual semua pembarisnya dengan harga RM1 dan pensel dengan harga 80 sen setiap satu. Cari keuntungan yang diperolehi dalam sen.  
*Carmen buys  $p$  rulers at a price of 70 cent each and  $q$  pencils at a price of 60 cent each. She sells all the rulers at a price of RM1 each and all the pencils at a price of 80 sen each. Find the profit that she earn in cent.*
- A  $10p + 20q$   
B  $1 - 80p + 20q^2$   
C  $30p + 20q$   
D  $20p + 30q$



11. Rajah 5 menunjukkan graf  $y = \cos x$   
*Diagram 5 shows a graph of  $y = \cos x$*

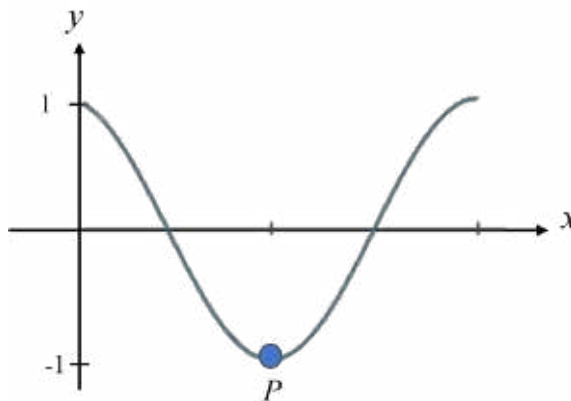

Rajah 5  
 Diagram 5

Nyatakan koordinat bagi  $P$

*State the coordinate of  $P$*

- A**  $(90^\circ, -1)$   
**B**  $(180^\circ, -1)$   
**C**  $(270^\circ, -1)$   
**D**  $(360^\circ, -1)$
12.  $\begin{pmatrix} 2 & -7 & 15 \\ 6 & 13 & 8 \end{pmatrix}$  ialah satu matriks peringkat  $m \times n$ . Apakah nilai  $m$  dan  $n$ ?

$\begin{pmatrix} 2 & -7 & 15 \\ 6 & 13 & 8 \end{pmatrix}$  is a  $m \times n$  matrix. What are the value of  $m$  and of  $n$ ?

- A**  $m = 2, n = 3$   
**B**  $m = 3, n = 2$   
**C**  $m = 2, n = 1$   
**D**  $m = 3, n = 3$

13. Rajah 6 menunjukkan dua bangunan tegak di atas satah mengufuk . $P$  dan  $Q$  adalah dua titik pada dua bangunan itu.

*Diagram 6 shows two vertical buildings on a horizontal plane.  $P$  and  $Q$  are two points on the two buildings.*

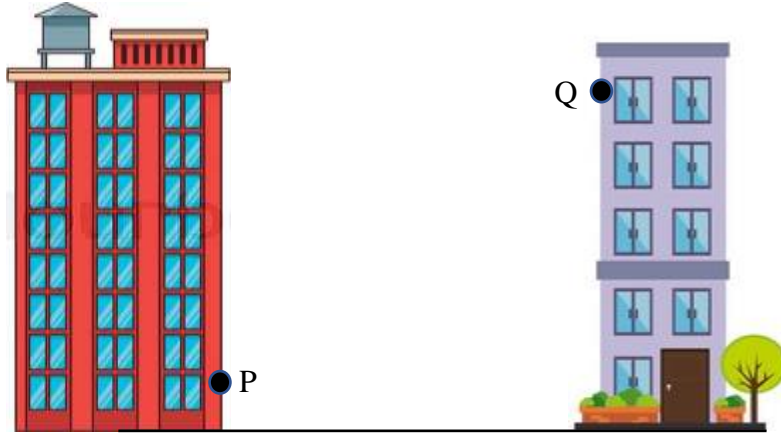

Rajah 6  
Diagrams 6

Titik  $R$  berada tegak di atas  $P$ , pada paras yang sama dengan  $Q$ . Titik  $S$  berada tegak di bawah  $Q$ , pada paras yang sama dengan  $P$ . Rajah yang manakah sudut dongakan,  $\theta$ , titik  $Q$  dari titik  $P$ ?

*Point  $R$  is vertically above  $P$ , at the same level as  $Q$ . Point  $S$  is vertically below  $Q$ , at the same level as  $P$ . Which diagram shows the angle,  $\theta$  of the point  $Q$  from point  $P$ ?*

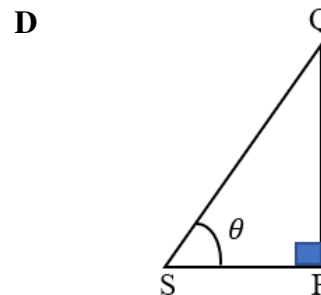
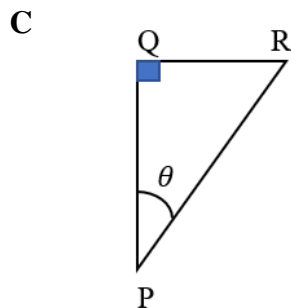
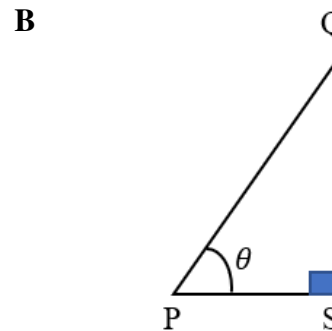
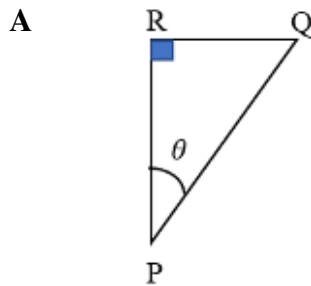

14. Kelab 3R ingin mengadakan kempen kitar semula di kawasan kejiranan. Mereka mendirikan pusat sehenti pengumpulan bahan kitar semula dan ingin mengkaji kadar penggunaannya. Antara berikut, yang manakah merupakan andaian yang betul tentang bilangan penduduk yang akan menggunakan pusat sehenti itu?

*The 3R Club would like to hold a recycling campaign in the neighborhood. They set up a one-stop center for the collection of recycled materials and want to study the rate of its use. Which of the following is a correct assumption about the number of residents who will use the one-stop center?*

- A** 100% orang yang berada berdekatan pusat sehenti akan menggunakannya.  
*100% of the people near the one stop center would use it.*
- B** 90% orang yang berada berdekatan pusat sehenti akan menggunakannya kerana rumah mereka berada dalam jarak 0.5 km dari pusat sehenti.  
*90% of the people near the one-shop center would use it as their house is within 05 km from the one-stop center.*
- C** 20% orang yang berada berdekatan pusat sehenti akan menggunakannya berdasarkan kajian sebelumnya.  
*20% of the people near the one-stop center would use it based on a previous study.*
- D** Tiada orang yang berada berdekatan pusat sehenti akan menggunakannya.  
*None of the people near the one-stop center would use it.*
15. Antara garis nombor yang berikut, manakah mewakili ketaksamaan linear  $-7 \leq 4x + 1 < 13$ ?

*Which of the following number lines represents the linear inequalities  $-7 \leq 4x + 1 < 13$ ?*

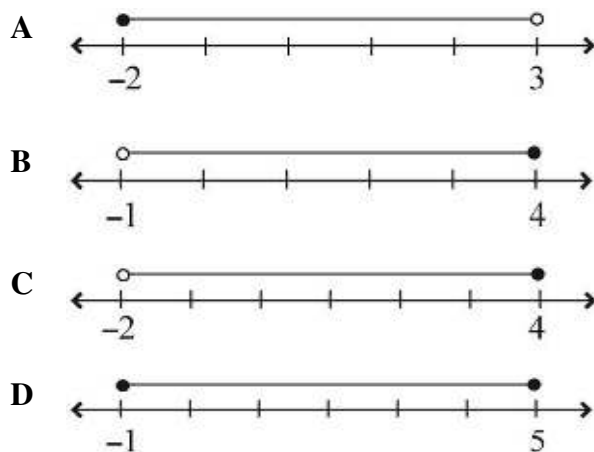

16. Gambar rajah Venn dalam Rajah 7 menunjukkan set semesta  $\xi$ , set K, dan set L.  
*The Venn diagram in Diagram 73 shows the universal set  $\xi$ , set K and set L.*

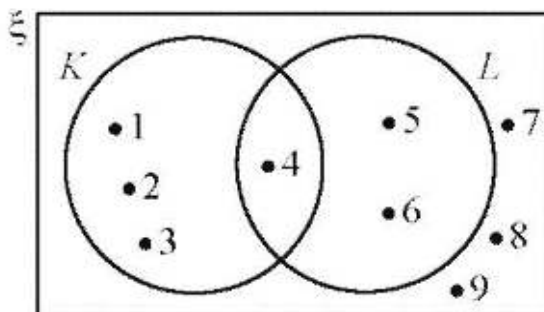

Rajah 7

Diagram 7

Senaraikan semua unsur bagi set L'.

*List all the elements of set L'.*

- A** {1, 2, 3}  
**B** {1, 2, 3, 4}  
**C** {1, 2, 3, 7, 8, 9}  
**D** {1, 2, 3, 4, 7, 8, 9}
17.  $9y^6 \div 27y^2 =$

- A**  $\frac{1}{3}y^3$   
**B**  $\frac{1}{3}y^4$   
**C**  $\frac{1}{9}y^3$   
**D**  $\frac{1}{9}y^4$

18. Berdasarkan Rajah 8, tentukan julat dan julat antara kuartil yang betul bagi plot kotak.  
Based on Diagram 8, determine the range and interquartile range for the box plot.

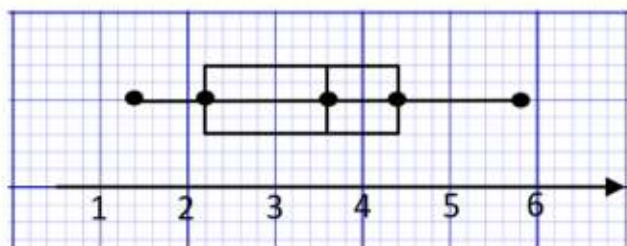

Rajah 8

Diagram 8

|   | Julat / Range | Julat antara kuartil / Interquartile range |
|---|---------------|--|
| A | 2.1           | 4.2  |
| B | 2.2           | 4.4  |
| C | 4.2           | 2.1  |
| D | 4.4           | 2.2  |

19. Rajah 9 menunjukkan garis lurus.

Diagram 9 shows a straight line.

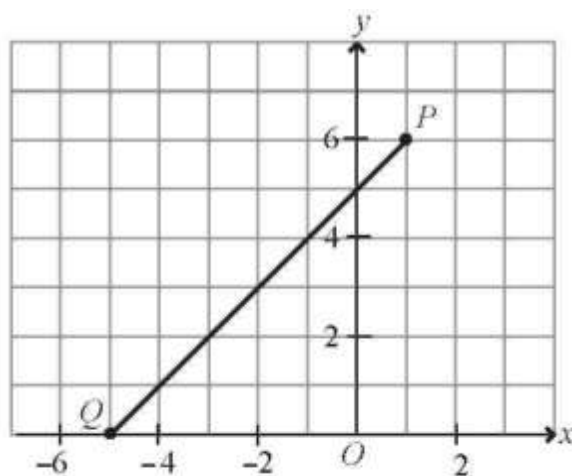

Rajah 9

Diagram 9

Kecerunan PQ ialah

The gradient of PQ is

- A 1  
B 9  
C  $-\frac{1}{9}$   
D -1

20. Rajah 10 menunjukkan kad-kad bernombor di dalam sebuah kotak.

*Diagram 10 shows numbered cards in a box.*

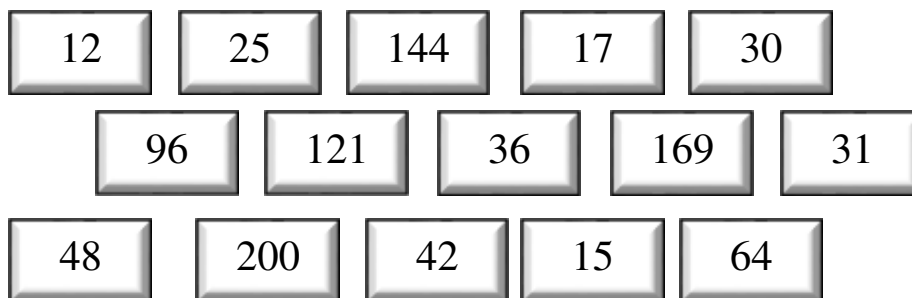

Rajah 10

*Diagram 10*

Satu kad dipilih secara rawak daripada kotak itu.

Cari kebarangkalian bahawa kad yang dipilih ialah nombor kuasa dua.

*A card is chosen at random from the box.*

*Find the probability that the card chosen is perfect square number.*

- A  $\frac{2}{5}$   
 B  $\frac{2}{3}$   
 C  $\frac{1}{5}$   
 D  $\frac{1}{3}$

21. Diberi X berubah secara langsung dengan punca kuasa Y. Nyatakan hubungan antara X dan Y.

*Given X varies directly as the square root of Y. State the relationship between X and Y.*

- A  $X \propto \frac{1}{Y^2}$   
 B  $X \propto Y^2$   
 C  $X \propto \sqrt{Y}$   
 D  $X \propto \frac{1}{\sqrt{Y}}$

22. Bundarkan 59 735 betul kepada tiga angka bererti  
*Round off 59 735 correct to three significant figures.*
- A 597  
B 59 700  
C 59 740  
D 59 800
23. Diberi  $125^n \times \frac{1}{25} = 625^n$ ., cari nilai n.  
*Given that  $125^n \times \frac{1}{25} = 625^n$ , find the value of n.*
- A -2  
B 2  
C -1  
D 3
24. Encik Raju membeli 2 500 unit saham Syarikat Cekap Berhad pada harga RM 1.60 seunit. Pada akhir tahun, syarikat itu membayar dividen sebanyak 4% kepada semua pemegang saham syarikat. Pada tahun berikutnya, Encik Raju telah menjual semua sahamnya apabila harga saham meningkat kepada RM1.80 seunit. Berapakah nilai pulangan pelaburan bagi Encik Raju?  
*Mr Raju bought 2 500 share units of Syarikat Cekap Berhad at RM 1.60 per unit. At the end of the year, the company paid a dividend of 4 % to all of its shareholders. In the following year, Mr Raju sold all his shares when the share price rose to RM 1.80 per unit. What is the return of investment for Mr Raju?*
- A 11.5 %  
B 12.5 %  
C 15.1 %  
D 16.5 %

25. Perimeter sebuah segi empat tepat ialah  $1.6 \times 10^{-1}$  m. Diberi panjangnya ialah  $5.0 \times 10^{-2}$  m, cari lebarnya, dalam m.

*The perimeter of a rectangle is  $1.6 \times 10^{-1}$  m. Given the length is  $5.0 \times 10^{-2}$  m, find the width, in m.*

- A  $3.0 \times 10^{-2}$
- B  $3.2 \times 10^{-2}$
- C  $1.1 \times 10^{-1}$
- D  $6.0 \times 10^{-1}$

26. Rajah 11 menunjukkan sebuah pentagon PQRST. Garis lurus PQ adalah selari dengan garis lurus UTS.

*Diagram 11 shows a pentagon PQRST. Straight line PQ is parallel to straight line UTS.*

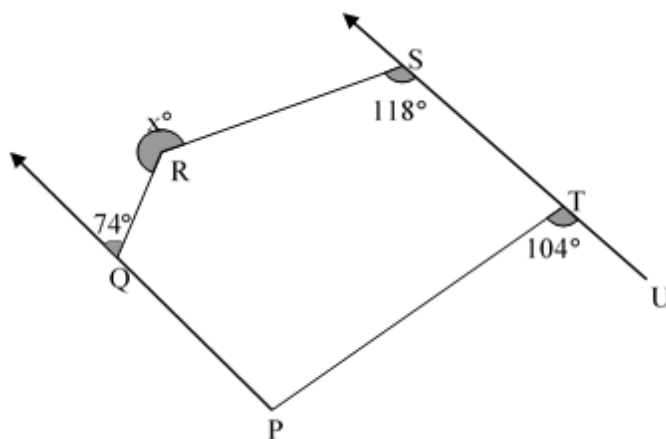

Rajah 11

Diagram 11

Cari nilai  $x$ .

*Find the value of  $x$ .*

- A 136
- B 224
- C 296
- D 372



27. Dalam Rajah 12, JKLQR ialah sebuah pentagon sekata dan PQL ialah sebuah segitiga sama kaki. PQRS ialah sebahagian daripada sebuah poligon dengan  $n$  sisi.

*In Diagram 12, JKLQR is a regular pentagon and PQL is an isosceles triangle. PQRS is a part of a polygon with  $n$  sides.*

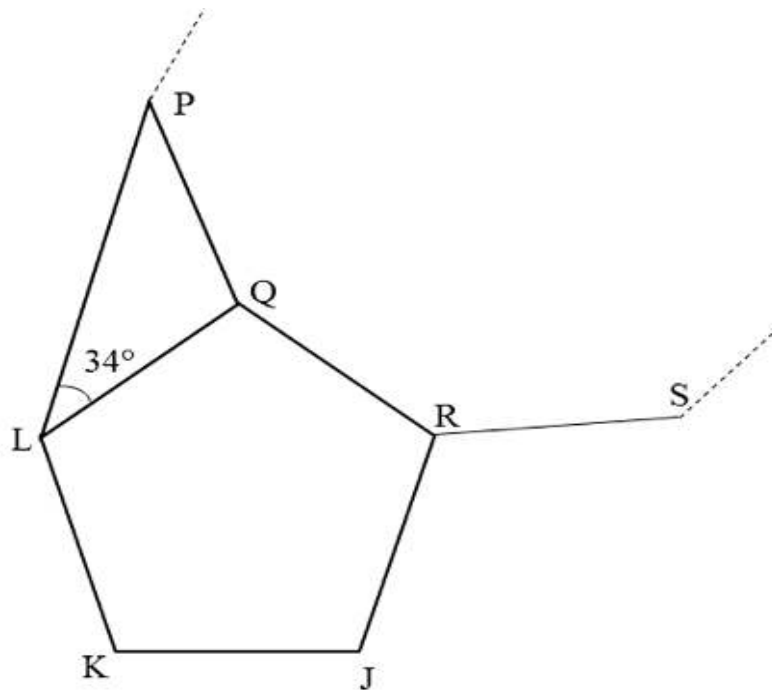

Rajah 12  
Diagram 12

Cari nilai  $n$ .

*Find the value of  $n$ .*

- A 9
- B 10
- C 11
- D 12

28. Pendapatan tahunan Encik Safri pada tahun 2020 ialah RM 75 650. Dia telah menderma RM 120 kepada sebuah badan kebajikan yang diluluskan oleh kerajaan. Dia juga membayar zakat berjumlah berjumlah RM 320. Jadual 1, menunjukkan pelepasan cukai yang dituntut oleh Encik Safri.

*Mr Safri's annual income in 2020 is RM 75,650. He has donated RM 120 to a government -approved charity. He also paid zakat amounting to RM 320. Table 1, shows the tax relief claimed by Mr Safri.*

| Pelepasan cukai<br><i>Tax relief</i>                     | Amaun (RM)<br><i>Amount (RM)</i> |
|--|----------------------------------|
| Individu / <i>Individual</i>                             | 9000                             |
| Ibu bapa / <i>Parent</i>                                 | 3000                             |
| Gaya hidup / <i>Lifestyle</i>                            | 750                              |
| Insurans hayat dan KWSP<br><i>Life insurance and EPF</i> | 7000                             |
| Insurans Perubatan<br><i>Medical insurance</i>           | 1700                             |

Jadual 1

*Table 1*

Hitung pendapatan bercukai Encik Safri pada tahun 2020.

*Calculate Mr. Safri's chargeable income in 2020.*

- A RM 53 360
- B RM 54 080
- C RM 53 760
- D RM 54 200

29. Apakah maksud ko-insurans 80/20 ?

*What does 80/20 co-insurance mean?*

**A** Pemegang polisi menanggung 20 % daripada jumlah kerugian.

*The policyholder bears 20 % of the total loss.*

**B** Pemegang polisi membayar 20% daripada premium.

*The policyholder pays 20% of the premium.*

**C** Pemegang polisi akan menerima 80% dari nilai muka

*Police holder will receive 80% of advance value*

**D** Pemegang polisi menanggung 80% daripada jumlah kerugian

*Policyholders bear 80% of the total loss*

30. Rajah 13 menunjukkan sebatang tiang yang berjarak 42 m dari sebuah rumah api pada satah mengufuk. Sudut dongakan puncak rumah api dari puncak tiang itu ialah  $34^\circ$ .

*Diagram 13 shows a pole on the horizontal ground 42 m from a lighthouse. The angle of elevation of the top of the lighthouse from the peak of the pole is  $34^\circ$ .*

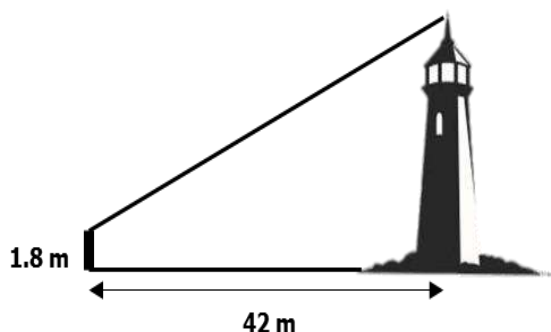

Rajah 13

Diagram 13

Hitung tinggi, dalam m, rumah api itu.

*Calculate the height, in m, of the lighthouse.*

**A** 26.53

**B** 28.24

**C** 30.13

**D** 32.17

31.  $\frac{5(q-1)}{2pq} - \frac{3}{4p} =$

A  $\frac{5q-8}{4pq}$

B  $\frac{7q-10}{4pq}$

C  $\frac{5q-4}{4pq}$

D  $\frac{2q-5}{2pq}$

32. Diberi  $\frac{4y-7}{2} = 6y - 3$ , cari nilai  $y$ .

*Given that  $\frac{4y-7}{2} = 6y - 3$ , find the value of  $y$ .*

A  $-\frac{1}{8}$

B  $-\frac{1}{4}$

C  $\frac{13}{8}$

D  $\frac{13}{16}$

33. Penyelesaian bagi  $36 - x > \frac{7}{2}x - 18$  ialah

*The solution for  $36 - x > \frac{7}{2}x - 18$  is*

A  $x > 29$

B  $x < 29$

C  $x > 12$

D  $x < 12$

34. Rajah 14 ialah sebuah carta palang yang menunjukkan bilangan buah-buahan yang dijual dalam lima bulan.

*Diagram 14 is a bar chart showing the number of fruits sold in five months.*

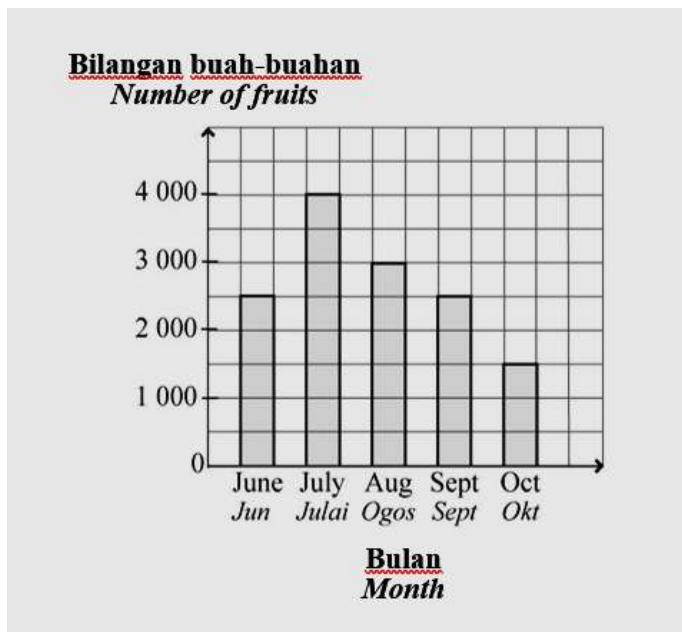

Rajah 14

Diagram 14

Cari min bagi buah-buahan yang telah dijual.  
*Find the mean of the fruits sold.*

- A 2 300
- B 2 600
- C 2 700
- D 3 000

35. Rajah 15 menunjukkan graf berpemberat dan tidak terarah. Heliza melukis satu pokok dengan jumlah pemberat minimum berdasarkan graf itu.  
*Diagram 15 shows a weighted and undirected graph. Heliza draws a tree with a minimum amount of weights based on the graph.*

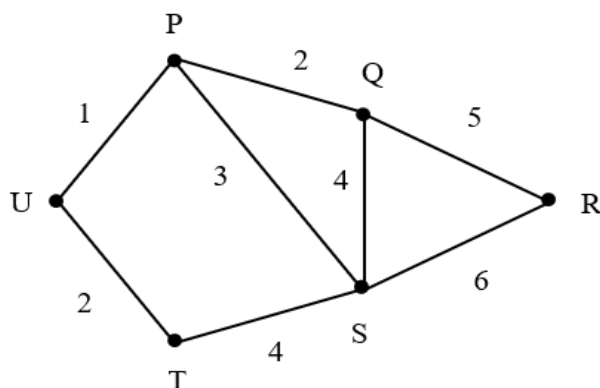

Rajah 15

Diagram 15

Hitung jumlah pemberat minimum tersebut.  
*Calculate the minimum number of weights.*

- A 12  
 B 13  
 C 14  
 D 15
36. Diberi bahawa  $P \propto \frac{1}{Q\sqrt{R}}$ , dan  $P = 2$  apabila  $Q = 4$  dan  $R = 9$ . Hitung nilai  $R$  apabila  $P = 4$  dan  $Q = \frac{1}{2}$ .  
*Given  $P \propto \frac{1}{Q\sqrt{R}}$ , and  $P = 2$  when  $Q = 4$  dan  $R = 9$ . Calculate the value of  $R$  when  $P = 4$  and  $Q = \frac{1}{2}$ .*
- A 64  
 B 100  
 C 121  
 D 144

37. Rajah 16 menunjukkan gambar rajah Venn dengan set  $M = \{\text{murid yang menghadiri tuisyen matematik}\}$ , set  $E = \{\text{murid yang menghadiri tuisyen Bahasa Inggeris}\}$  dan  $S = \{\text{murid yang menghadiri tuisyen Sains}\}$

*Diagram 16 shows a Venn diagram with set  $M = \{\text{pupils attending mathematics tuition}\}$ , set  $E = \{\text{pupils attending English tuition}\}$  and  $S = \{\text{pupils attending Science tuition}\}$*

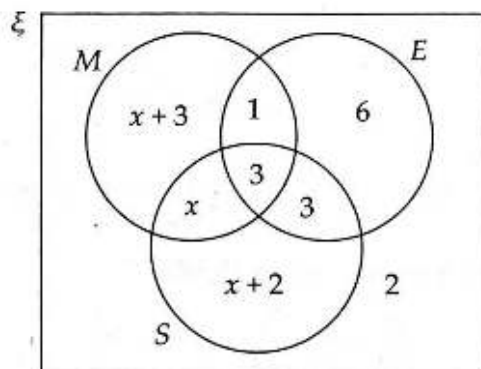

Rajah 16

Diagram 16

Diberi bahawa  $n(\xi) = 26$ , cari bilangan murid yang menghadiri tuisyen Matematik sahaja.

*Given that  $n(\xi) = 26$ , find the number of students attending Mathematics tuition only.*

- A 2  
 B 3  
 C 4  
 D 5
38. Cari pintasan-y bagi garis lurus yang melalui titik(1,4) dan titik (-1,1)  
*Find the y-intercept of the straight line passing through point (1,4) and point (-1,1)*

- A  $\frac{-13}{2}$   
 B  $\frac{-3}{5}$   
 C  $\frac{5}{2}$   
 D  $\frac{18}{5}$

39. Jadual 2 menunjukkan bilangan murid dari tiga kelas yang menghadiri suatu kem motivasi.

*Table 2 shows the number of students from the three classes who attended a motivational camp.*

|                           | 5P | 5Q | 5R |
|---------------------------|----|----|----|
| Lelaki<br><i>Boys</i>     | 10 | 21 | 15 |
| Perempuan<br><i>Girls</i> | 23 | 12 | 9  |

Jadual 2  
Table 2

Seorang murid dipilih secara rawak dari kumpulan itu. Hitung kebarangkalian bahawa seorang murid dari kelas 5R terpilih.

*One student was randomly selected from the group. Calculate the probability that a student from class 5R is selected.*

- A  $\frac{1}{6}$   
 B  $\frac{1}{10}$   
 C  $\frac{4}{15}$   
 D  $\frac{11}{30}$

40. Diberi  $(k \ 5) \begin{pmatrix} 3 & 0 \\ -k & 1 \end{pmatrix} = (24 \ 5)$ , hitungkan nilai  $k$ .

*Given  $(k \ 5) \begin{pmatrix} 3 & 0 \\ -k & 1 \end{pmatrix} = (24 \ 5)$ , calculate the value of  $k$ .*

- A 3  
 B 8  
 C -1  
 D -12



**MAKLUMAT UNTUK CALON**  
***INFORMATION FOR CANDIDATES***

1. Kertas peperiksaan ini adalah dalam dwibahasa. Soalan dalam Bahasa Melayu mendahului soalan yang sepadan dalam Bahasa Inggeris.  
*This question paper is bilingual. Question in Malay language precede the corresponding question in the English language.*
2. Kertas peperiksaan ini mengandungi **40** soalan.  
*This question paper consists of **40** questions.*
3. Jawab **semua** soalan.  
*Answer **all** questions.*
4. Jawab setiap soalan dengan menghitamkan ruangan yang betul pada kertas jawapan objektif.  
*Answer each question by blackening the correct space on the objective answer sheet.*
5. Hitamkan **satu** ruangan sahaja bagi setiap soalan.  
*Blacken only **one** space for each question.*
6. Sekiranya anda hendak menukar jawapan, padamkan tanda yang telah dibuat. Kemudian hitamkan jawapan yang baharu.  
*If you wish to change your answer, erase the blackened mark that you have done. Then blacken the space for the new answer.*
7. Rajah yang mengiringi soalan tidak dilukis mengikut skala kecuali dinyatakan.  
*The diagrams in the questions provided are not drawn to scale unless stated.*
8. Satu senarai rumus disediakan di halaman 2 hingga 4.  
*A list of formulae is provided on the pages 2 to 4.*
9. Anda dibenarkan menggunakan kalkulator saintifik.  
*You may use a scientific calculator.*

NAMA: \_\_\_\_\_

NO. KAD PENGENALAN:

|  |  |  |  |  |  |  |  |  |  |  |  |  |  |  |  |  |  |  |  |
|--|--|--|--|--|--|--|--|--|--|--|--|--|--|--|--|--|--|--|--|
|  |  |  |  |  |  |  |  |  |  |  |  |  |  |  |  |  |  |  |  |
|--|--|--|--|--|--|--|--|--|--|--|--|--|--|--|--|--|--|--|--|

ANGKA GILIRAN:

|  |  |  |  |  |  |  |  |  |  |
|--|--|--|--|--|--|--|--|--|--|
|  |  |  |  |  |  |  |  |  |  |
|--|--|--|--|--|--|--|--|--|--|

**LOGO SEKOLAH**

**NAMA SEKOLAH**

**PEPERIKSAAN PERCUBAAN SPM  
TINGKATAN 5**

**MATHEMATICS**

**1449/2**

**Kertas 2 (Set 1)**

**Nombor**

$2\frac{1}{2}$  jam

**Dua jam tiga puluh minit**

**JANGAN BUKA KERTAS SOALAN INI SEHINGGA DIBERITAHU**

1. Tulis nama, nombor kad pengenalan dan angka giliran anda pada petak yang disediakan.
2. Kertas soalan ini adalah dalam dwibahasa
3. Soalan dalam Bahasa Melayu mendahului soalan yang sepadan dalam Bahasa Inggeris.
4. Calon dibenarkan menjawab keseluruhan atau sebahagian soalan sama ada dalam bahasa Inggeris atau bahasa Melayu.
5. Calon dikehendaki membaca maklumat di halaman belakang kertas soalan ini.

| Untuk Kegunaan Pemeriksa |        |              |                  |
|--------------------------|--------|--------------|------------------|
| Kod Pemeriksa:           |        |              |                  |
| Bahagian                 | Soalan | Markah Penuh | Markah diperoleh |
| A                        | 1      | 3            |                  |
|                          | 2      | 3            |                  |
|                          | 3      | 5            |                  |
|                          | 4      | 5            |                  |
|                          | 5      | 4            |                  |
|                          | 6      | 4            |                  |
|                          | 7      | 4            |                  |
|                          | 8      | 3            |                  |
|                          | 9      | 5            |                  |
|                          | 10     | 4            |                  |
| B                        | 11     | 9            |                  |
|                          | 12     | 9            |                  |
|                          | 13     | 9            |                  |
|                          | 14     | 9            |                  |
|                          | 15     | 9            |                  |
| C                        | 16     | 15           |                  |
|                          | 17     | 15           |                  |
| <b>JUMLAH</b>            |        | <b>100</b>   |                  |

Kertas soalan ini mengandungi 42 halaman bercetak

**RUMUS MATEMATIK**  
**MATHEMATICAL FORMULAE**

Rumus-rumus berikut boleh membantu anda menjawab soalan. Simbol-simbol yang diberi adalah yang biasa digunakan.

*The following formulae may be helpful in answering the questions. The symbols given are the ones commonly used.*

**NOMBOR DAN OPERASI**  
**NUMBERS AND OPERATIONS**

- |  |   |
|--|---|
| 1 $a^m \times a^n = a^{m+n}$   | 2 $a^m \div a^n = a^{m-n}$                |
| 3 $(a^m)^n = a^{mn}$   | 4 $a^{\frac{m}{n}} = (a^m)^{\frac{1}{n}}$ |
| 5     Faedah mudah / <i>Simple interest</i> , $I = Prt$                                      |   |
| 6     Faedah kompaun / <i>Compound interest</i> , $MV = P \left(1 + \frac{r}{n}\right)^{nt}$ |   |
| 7     Jumlah bayaran balik / <i>Total repayment</i> , $A = P + Prt$                          |   |

**PERKAITAN DAN ALGEBRA**  
**RELATIONSHIP AND ALGEBRA**

- 1     Jarak / *Distance* =  $\sqrt{(x_2 - x_1)^2 + (y_2 - y_1)^2}$
- 2     Titik tengah / *Midpoint*,  $(x, y) = \left(\frac{x_1 + x_2}{2}, \frac{y_1 + y_2}{2}\right)$
- 3     Laju purata =  $\frac{\text{Jumlah jarak}}{\text{Jumlah masa}}$
- Average speed* =  $\frac{\text{Total distance}}{\text{Total time}}$
- 4      $m = \frac{y_2 - y_1}{x_2 - x_1}$
- 5      $m = -\frac{\text{pintasan-}y}{\text{pintasan-}x}$
- $m = -\frac{y\text{-intercept}}{x\text{-intercept}}$
- 6      $A^{-1} = \frac{1}{ad - bc} \begin{pmatrix} d & -b \\ -c & a \end{pmatrix}$

**SUKATAN DAN GEOMETRI**  
**MEASUREMENT AND GEOMETRY**

- 1 Teorem Pythagoras / *Pythagoras Theorem*,  $c^2 = a^2 + b^2$
- 2 Hasil tambah sudut pedalaman poligon / *Sum of interior angles of a polygon*  
 $= (n - 2) \times 180^\circ$
- 3 Lilitan bulatan =  $\pi d = 2\pi j$   
*Circumference of circle* =  $\pi d = 2\pi r$
- 4 Luas bulatan =  $\pi j^2$   
*Area of circle* =  $\pi r^2$
- 5  $\frac{\text{Panjang lengkok}}{2\pi j} = \frac{\theta}{360^\circ}$   
 $\frac{\text{Arc length}}{2\pi r} = \frac{\theta}{360^\circ}$
- 6  $\frac{\text{Luas sektor}}{\pi j^2} = \frac{\theta}{360^\circ}$   
 $\frac{\text{Area of sector}}{\pi r^2} = \frac{\theta}{360^\circ}$
- 7 Luas layang =  $\frac{1}{2} \times$  hasil darab panjang dua pepenjuru  
*Area of kite* =  $\frac{1}{2} \times$  *product of two diagonals*
- 8 Luas trapezium =  $\frac{1}{2} \times$  hasil tambah dua sisi selari  $\times$  tinggi  
*Area of trapezium* =  $\frac{1}{2} \times$  *sum of two parallel sides*  $\times$  *height*
- 9 Luas permukaan silinder =  $2\pi j^2 + 2\pi jt$   
*Surface area of cylinder* =  $2\pi r^2 + 2\pi rh$
- 10 Luas permukaan kon =  $\pi j^2 + \pi js$   
*Surface area of cone* =  $\pi r^2 + \pi rs$
- 11 Luas permukaan sfera =  $4\pi j^2$   
*Surface area of sphere* =  $4\pi r^2$
- 12 Isi padu prisma = luas keratan rentas  $\times$  tinggi  
*Volume prism* = *area of cross section*  $\times$  *height*
- 13 Isi padu silinder =  $\pi j^2 t$   
*Volume of cylinder* =  $\pi r^2 h$

- 14 Isi padu kon =  $\frac{1}{3}\pi j^2 t$   
*Volume of cone* =  $\frac{1}{3}\pi r^2 h$
- 15 Isi padu sfera =  $\frac{4}{3}\pi j^3$   
*Volume of sphere* =  $\frac{4}{3}\pi r^3$
- 16 Isi padu piramid =  $\frac{1}{3} \times$  luas tapak  $\times$  tinggi  
*Area of trapezium* =  $\frac{1}{3} \times$  base area  $\times$  height
- 17 Faktor skala,  $k = \frac{PA'}{PA}$   
*Scale factor, k* =  $\frac{PA'}{PA}$
- 18 Luas imej =  $k^2 \times$  luas objek  
*Area of image* =  $k^2 \times$  area of object

**STATISTIK DAN KEBARANGKALIAN**  
**STATISTICS AND PROBABILITY**

- 1 Min / Mean,  $\bar{x} = \frac{\sum x}{N}$
- 2 Min / Mean,  $\bar{x} = \frac{\sum fx}{\sum f}$
- 3 Varians / Variance,  $\sigma^2 = \frac{\sum(x - \bar{x})^2}{N} = \frac{\sum x^2}{N} - \bar{x}^2$
- 4 Varians / Variance,  $\sigma^2 = \frac{\sum f(x - \bar{x})^2}{\sum f} = \frac{\sum fx^2}{\sum f} - \bar{x}^2$
- 5 Sisihan piawai / Standard deviation,  $\sigma = \sqrt{\frac{\sum(x - \bar{x})^2}{N}} = \sqrt{\frac{\sum x^2}{N} - \bar{x}^2}$
- 6 Sisihan piawai / Standard deviation,  $\sigma = \sqrt{\frac{\sum f(x - \bar{x})^2}{\sum f}} = \sqrt{\frac{\sum fx^2}{\sum f} - \bar{x}^2}$
- 7  $P(A) = \frac{n(A)}{n(S)}$
- 8  $P(A') = 1 - P(A)$

Untuk  
Kegunaan  
Pemeriksa

**Bahagian A**  
**Section A**  
**[40 markah / marks]**

Jawab **semua** soalan dalam bahagian ini.  
*Answer all questions in this section.*

- 1 Diberi isipadu pasu,  $P \text{ cm}^3$ , adalah berubah secara langsung dengan kuasa dua jejarinya,  $j$ . Dengan menggunakan  $k$  sebagai pemalar, ungkapkan  $k$  dalam sebutan  $P$  dan  $j$ . Seterusnya, hitung nilai  $k$  jika isipadu pasu itu ialah  $1\,250 \text{ cm}^3$  dan jejari baldi ialah  $25 \text{ cm}$ .

*Volume of a vase,  $P \text{ cm}^3$ , is varies directly as the square of its radius,  $j$ . By using  $k$  as a constant, express  $k$  in terms of  $P$  and  $j$ . Hence, calculate the value of  $k$  if the volume of the vase is  $1\,250 \text{ cm}^3$  and its radius is  $25 \text{ cm}$ .*

[3 markah / marks]

Jawapan / Answer:

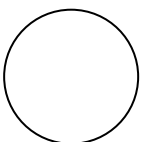

- 2 Jaya menyimpan RM13 500 di sebuah bank dengan kadar faedah mudah ialah 2.5% setahun. Beliau ingin membeli sebuah motosikal berharga RM14 500 melalui hasil simpanannya.  
Berapa lamakah tempoh penyimpanan yang diperlukan oleh Jaya?

*Untuk  
Kegunaan  
Pemeriksa*

*Jaya saves RM13 500 at a bank with a simple interest rate of 2.5% per annum. She wants to buy a motorcycle worth RM14 500 with her savings. How long does Jaya need to save?*

- (a) Kenal pasti dan definisikan masalah dalam persoalan di atas.

*Identify and define the problem.*

- (b) Tentukan andaian yang perlu dibuat.

*Determine the assumptions that need to be made.*

- (c) Kenal pasti pemboleh ubah dalam menyelesaikan masalah ini.

*Identify the variables in solving the problems.*

[3 markah / marks]

Jawapan / Answer :

(a)

(b)

(c)

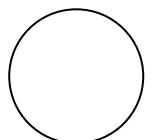

Untuk  
Kegunaan  
Pemeriksa

- 3 Rajah 1 menunjukkan 2 bekas berbentuk silinder yang sama saiz. Bekas P mengandungi bola tenis yang digunakan untuk latihan tenis. Bekas Q tidak mengandungi bola.

*Diagram 1 shows 2 cylindrical container of the same size. The P container contains tennis ball used for tennis training. The Q container does not contains ball.*



Rajah / Diagram 1

Diberi jejari bagi bola tenis ialah 3 cm. Jejari dan tinggi bagi kedua-dua bekas P dan Q ialah 15 cm dan 13 cm masing-masing.

*Given that the radius of a tennis ball is 3 cm. The radius and height of both containers P and Q are 15 cm and 13 cm respectively.*

Menggunakan  $\pi = \frac{22}{7}$ ,

Using  $\pi = \frac{22}{7}$ ,

- (a) Hitung isipadu bekas P.

*Calculate the volume of P container.*

[2 markah / marks]

- (b) Bola tenis daripada bekas P dimasukkan ke dalam bekas Q. Lebihan ruang isipadu bekas Q setelah diisi bola tenis ialah  $5798.57 \text{ cm}^3$ .  
Hitung bilangan bola tenis.

*A tennis ball from container P is inserted into container Q. The excess space volume of container Q after being filled with a tennis ball is  $5798.57 \text{ cm}^3$ .*

*Calculate the number of tennis balls.*

[3 markah / marks]



Jawapan / Answer:

(a)

(b)

*Untuk  
Kegunaan  
Pemeriksa*

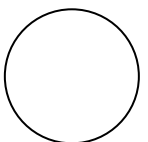

Untuk  
Kegunaan  
Pemeriksa

- 4 Susan akan menyambut harijadinya pada hujung minggu. Beliau pergi ke pasaraya untuk membeli buah epal hijau dan epal merah untuk tetamunya. Harga bagi sebiji epal hijau ialah RM0.80, manakala harga bagi sebiji epal merah ialah RM1.20. Jumlah keseluruhan buah epal yang diperlukan ialah 100 biji. Jumlah wang yang dibelanjakan untuk membeli buah epal berkenaan ialah RM 108.

*Susan will be celebrate her birthday over the weekend. She went to the supermarket to buy green apples and red apples for her guest. The price for a green apple is RM0.80, while the price for a red apple is RM1.20. The total apples needed are 100. The amount of money spent to buy apples is RM 108.*

Dengan menggunakan kaedah matriks, hitung bilangan buah epal hijau dan epal merah yang diperlukan untuk majlis harijadinya.

*By using matrix method, calculate the number of green apples and red apples needed for her birthday party.*

[5 markah / marks]

Jawapan / Answer:

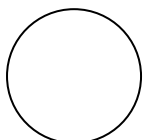

- 5 Jadual 1 menunjukkan tambang bas, dalam RM, yang dinaiki oleh 7 orang pekerja Kilang Isuzu mengikut jarak dari rumah masing-masing ke tempat kerja.

Untuk  
Kegunaan  
Pemeriksa

Table 1 shows the bus fares, in RM, taken by 7 Isuzu's workers according to the distance from their respective homes to the workplace.

| Jarak<br><i>Distance</i> | Tambang bas (RM)<br><i>Bus fares (RM)</i> |
|--------------------------|---|
| J, K                     | 2   |
| L, K                     | 4   |
| M, K                     | 5   |
| K, K                     | 10  |
| J, L                     | 7   |
| M, N                     | 8   |

Jadual / Table 1

- (a) Berdasarkan maklumat dalam Jadual 1, lengkapkan graf terarah dan berpemberat di ruang jawapan.

*Based on the information in Table 1, complete the directed weighted graph in the answer space.*

- (b) Lukis satu pokok berpemberat minimum.

[2 markah / marks]

*Draw a tree with minimum total weight.*

[2 markah / marks]

Jawapan / answer:

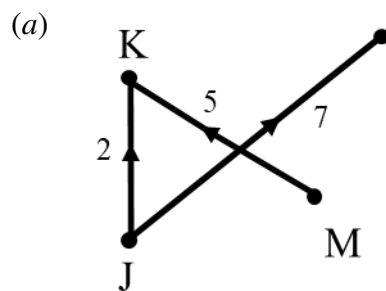

- (b)

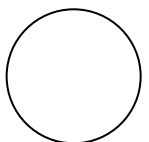

Untuk  
Kegunaan  
Pemeriksa

- 6 Lakar graf fungsi  $y = 3 \sin 2x + 1$  bagi  $0^\circ \leq x \leq 360^\circ$ .

*Sketch the graph of the function  $y = 3 \sin 2x + 1$  for  $0^\circ \leq x \leq 360^\circ$ .*

[4 markah / marks]

Jawapan / Answer:

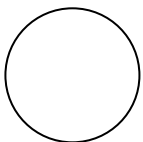

- 7 Rumah En. Halim diinsuranskan dengan insurans kebakaran yang memperuntukkan ko-insurans untuk menginsuranskan 75% daripada nilai boleh insurans rumahnya. Nilai boleh insurans rumah itu ialah RM500 000.

Untuk  
Kegunaan  
Pemeriksa

*Mr. Halim's house is insured with fire insurance which provides for co-insurance to insure 75% of his home's insurable value. The insurable value of his house is RM500 000.*

- (a) Kira jumlah insurans yang perlu diambil oleh En. Halim.

*Calculate the amount of insurance that Mr. Halim needs to take.*

[2 markah / marks]

- (b) En. Halim telah menginsuranskan rumahnya mengikut jumlah dalam soalan (a). Jika keseluruhan rumahnya terbakar, adakah En. Halim akan menerima bayaran pampasan sebanyak RM500 000? Berikan justifikasi anda.

*Mr. Halim has insured his house according to the amount in question (a). If his whole house is on fire, will Mr. Halim receive compensation of RM500 000? Give your justification.*

[2 markah / marks]

Jawapan / Answer:

(a)

(b)

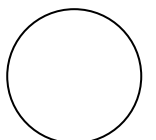

Untuk  
Kegunaan  
Pemeriksa

- 8 Hassan bercadang membina sebuah kolam renang di belakang rumahnya. Rajah 2 menunjukkan pelan kolam renang yang dilukis oleh Hassan.

*Hassan plans to build a swimming pool in the backyard of her house. Diagram 2 shows the pool plan drawn by Hassan.*

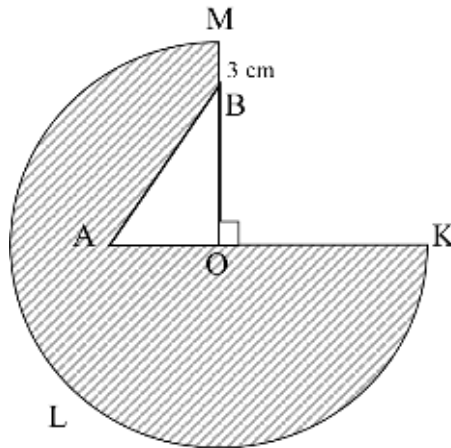

Rajah / Diagram 2

Kawasan yang berlorek OKLM menunjukkan paras air kolam yang cetek, manakala kawasan kolam AOB pula adalah bahagian paras air yang dalam. Diberi bahawa Panjang jejari OA ialah 4 m dan  $OM:OB = 3:2$ . Hitung luas, dalam  $m^2$ , kawasan yang berlorek.

*The shaded area OKLM shows the shallow water level of the pool, while the pool area AOB is the deep-water level. Given that the radius OA is 4 m and  $OM:OB = 3:2$ . Calculate the area, in  $m^2$ , of the shaded region.*

(Gunakan  $\pi = \frac{22}{7}$  , Using  $\pi = \frac{22}{7}$  )

[3 markah /marks]

Jawapan / Answer:

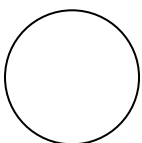

Untuk  
Kegunaan  
Pemeriksa

- 9 Lengkapi Jadual 2 di ruangan jawapan dan seterusnya dengan menggunakan skala 2 cm kepada 1 unit pada paksi-x dan 2 cm kepada 2 unit pada paksi-y, lukis graf bagi fungsi  $y = 8x - x^2$  untuk  $0 \leq x \leq 8$ .

*Complete Table 2 in the answer space and then by using a scale of 2 cm to 1 unit on the x-axis and 2 cm to 2 units on the y-axis, draw the graph of  $y = 8x - x^2$  for  $0 \leq x \leq 8$ .*

[5 markah / marks]

Jawapan / Answer :

|     |   |   |    |    |    |   |    |   |   |
|-----|---|---|----|----|----|---|----|---|---|
| $x$ | 0 | 1 | 2  | 3  | 4  | 5 | 6  | 7 | 8 |
| $y$ | 0 |   | 12 | 15 | 16 |   | 12 | 7 | 0 |

Jadual / Table 2

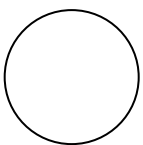
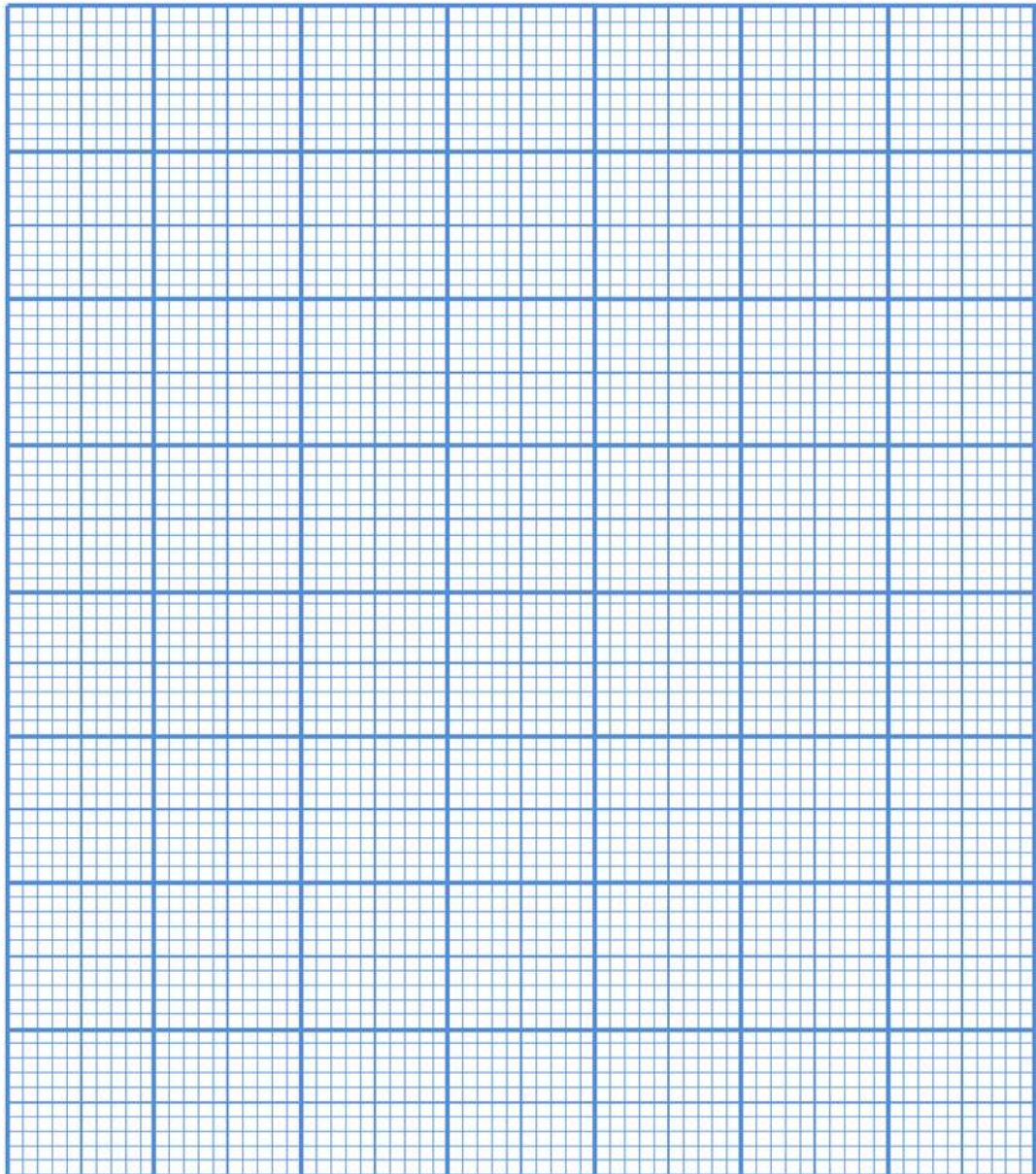

Untuk  
Kegunaan  
Pemeriksa

- 10 Puan Rohana meminta setiap murid menggunting kepingan kad bod berbentuk segiempat sama. Beliau melabel 9 keping kad dengan huruf dan nombor seperti yang ditunjukkan dalam Rajah 3.

*Puan Rohana asks each students to cut a cardboard to square. She labels nine cards with letters and numbers as shown in diagram 3.*



Rajah / Diagram 3

Dia meletakkan semua kad berlabel huruf ke dalam kotak A dan semua kad berlabel nombor ke dalam kotak B. Seorang murid mengeluarkan kad secara rawak daripada setiap kotak itu.

*She puts all the cards labelled with letters into box A and all cards labelled with numbers into box B. A students randomly draws a card from each box.*

- (a) Senaraikan ruang sampel.

*List the sample space.*

- (b) Dengan menyenaraikan semua kesudahan yang mungkin bagi peristiwa itu, cari kebarangkalian bahawa sekeping kad dilabel dengan huruf konsonan dan sekeping kad lagi dilabel dengan nombor ganjil.

*By listing down all the possible outcomes of the event, find the probability that one card is labelled with a consonan and the other card is labelled with an odd number.*

[4 markah / marks]

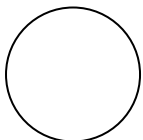



Jawapan / Answer:

*Untuk  
Kegunaan  
Pemeriksa*

(a)

(b) (i)

(ii)

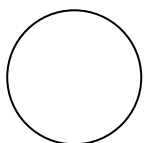

**Bahagian/Section B**  
**[45 markah/marks]**

Jawab **semua** soalan dalam bahagian ini.  
*Answer **all** questions from this section.*

- 11 (a) Encik Azman bekerja sebagai seorang penyelia kilang dengan gaji sebanyak RM4 200 sebulan. Dia menyimpan 10% daripada jumlah pendapatan bulannya sebagai simpanan tetap bulanan dan RM250 sebagai simpanan untuk dana kecemasan. Encik Azman juga akan pergi bercuti dengan jumlah anggaran perbelanjaan yang diperlukan ialah RM520. Jadual 3 menunjukkan anggaran perbelanjaan Encik Azman bagi bulan Oktober.

*Encik Azman works as a factory supervisor with the salary of RM4 200 per month. He saves 10% of his monthly income as the fixed monthly savings and RM250 as the savings for emergency fund. He also will go on a holiday with the estimation cost needed is RM520. Table 3 shows his estimated expenses for October.*

| <b>Perbelanjaan<br/>Expenses</b>   | <b>RM</b> |
|--|-----------|
| Makanan<br><i>Food</i>   | 1050      |
| Bil air, elektrik dan telefon<br><i>Water, electricity and<br/>telephone bills</i> | 270       |
| Gas dan petrol<br><i>Gas and petrol</i>  | 120       |
| Insurans peribadi<br><i>Personal insurance</i>                                     | 85        |
| Bayaran pinjaman kenderaan<br><i>Vehicle loan payment</i>                          | 550       |
| Sewa rumah<br><i>House rent</i>  | 600       |
| Yuran bulanan gimnasium<br><i>Gymnasium monthly fee</i>                            | 70        |

Jadual / Table 3

- (a) Lengkapkan, di ruang jawapan, jadual pelan kewangan untuk Encik Azman.

*Complete, in the answer space, the financial plan for Encik Azman.*

[7 markah/ marks]

- (b) Encik Azman bercadang untuk membeli mesin pengering pakaian yang berharga RM1 700 dalam tempoh 6 bulan. Berdasarkan pelan kewangan Encik Azman, dapatkah Encik Azman membeli mesin pengering pakaian dalam tempoh yang dikehendaki? Terangkan jawapan anda.

*Encik Azman plans to buy a dryer costs RM1 700 within 6 months. Based on Encik Azman's financial plan, will Encik Azman be able to buy the dryer within the time estimated? Explain your answer.*

[2 markah/ marks]

Jawapan / Answer:

Untuk  
Kegunaan  
Pemeriksa

(a)

| <b>Pendapatan dan Perbelanjaan</b><br><i>Income and Expenditure</i>  | <b>RM</b> |  |
|--|-----------|--|
| <b>pendapatan bersih / net income :</b>  |           |  |
| gaji bersih / net salary   | 4 200     |  |
| pendapatan pasif / passive income  | 0         |  |
| jumlah pendapatan bulanan /<br><i>total monthly income</i>   | 4 200     |  |
| tolak simpanan tetap bulanan (10%<br>daripada pendapatan bulanan)/<br><i>minus fixed monthly savings (10% of the<br/>monthly income)</i> |           |  |
| tolak simpanan untuk dana kecemasan<br><i>minus savings for emergency fund</i>   | 250       |  |
| baki pendapatan /<br><i>income balance</i>   |           |  |
| <b>tolak perbelanjaan tetap bulanan/<br/><i>minus monthly fixed expenses</i></b>   |           |  |
| jumlah perbelanjaan tetap bulanan/<br><i>total monthly fixed expenses</i>  |           |  |
| <b>tolak perbelanjaan tidak tetap bulanan/<br/><i>minus monthly variable expenses</i></b>  |           |  |
| jumlah perbelanjaan tidak tetap bulanan/<br><i>total monthly variable expenses</i>   |           |  |
| pendapatan lebihan/ <i>surplus of income</i>   |           |  |

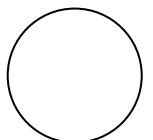

(b)

*Untuk  
Kegunaan  
Pemeriksa*

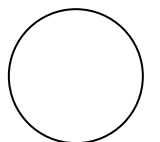

- 12 Rajah 4 menunjukkan graf jarak-masa bagi Sabri, Tan dan Uday dalam acara berbasikal 40 km.

Diagram 4 shows the distance-time graph of Sabri, Tan and Uday in a 40 km race.

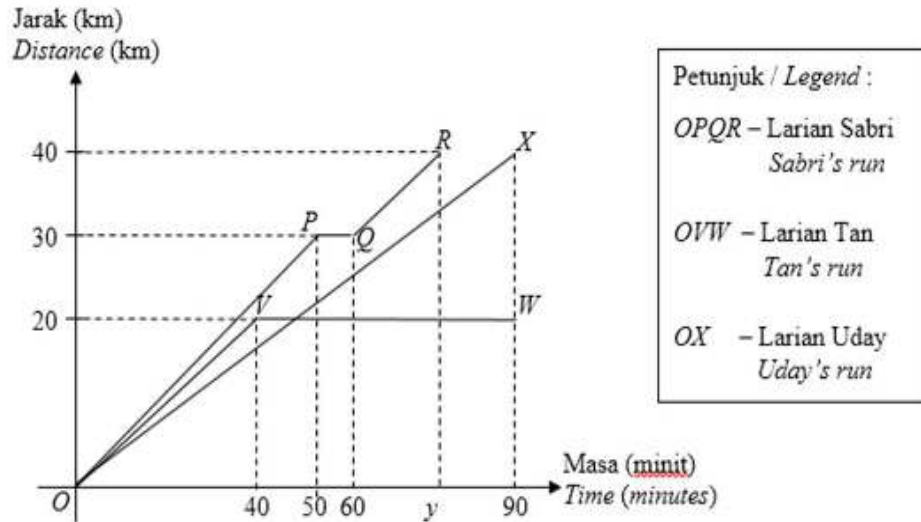

Rajah / Diagram 4

- (a) i. Siapakah yang tidak menghabiskan acara larian itu?  
Who did not finish the race?  
[2 markah/ marks]
- ii. Siapakah yang memenangi acara larian itu?  
Who won the race?  
[2 markah/ marks]
- (b) Hitung jarak, dalam km, penunggang basikal yang tidak menghabiskan perlumbaan itu dari garisan penamat apabila dia berhenti mengayuh basikal.  
Calculate the distance, in km, of the cyclist who did not finish the race from the finishing line when he stopped cycling.  
[1 markah/ marks]
- (c) Hitung laju purata, dalam  $\text{kmj}^{-1}$ , bagi Uday.  
Calculate the average speed, in  $\text{kmh}^{-1}$ , of Uday.  
[2 markah/ marks]

- (d) i. Sabri terjatuh semasa perlumbaan. Selepas itu, dia meneruskan perlumbaan sehingga ke garisan penamat. Nyatakan tempoh masa, dalam minit, sebelum Sabri meneruskan perlumbaan.

*Sabri fell over during the race. After that, he continued his race till the finishing line. State the duration of time, in minutes, before Sabri continued his race.*

[1 markah/ marks]

- ii. Jika laju purata bagi Sabri ialah  $32 \text{ km j}^{-1}$ , cari nilai  $y$ .

*If Sabri's average speed is  $32 \text{ km h}^{-1}$ , find the value of  $y$ .*

[2 markah/ marks]

Untuk  
Kegunaan  
Pemeriksa

Jawapan / Answer:

(a) (i)

(ii)

(b)

(c)

(d) i.

ii.

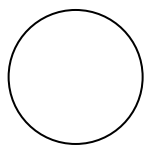



- 13 Jadual 4 menunjukkan kekerapan bagi skor yang diperolehi oleh sekumpulan pelajar dalam suatu kuiz pengetahuan am.

*Table 4 shows the frequency of scores obtained by a group of students in a general knowledge quiz.*

|                                      |   |   |   |   |   |    |
|--------------------------------------|---|---|---|---|---|----|
| <b>Skor</b><br><i>Score</i>          | 5 | 6 | 7 | 8 | 9 | 10 |
| <b>Kekerapan</b><br><i>Frequency</i> | 3 | 5 | 8 | 4 | 7 | 1  |

Jadual / Table 4

- (a) Berdasarkan Jadual 4, cari julat dan julat antara kuartil. Seterusnya, lengkapkan plot kotak di ruang jawapan.

*Based on Table 4, find the range and interquartile range. Hence, complete the box plot in the answer space.*

[5 markah/ marks]

- (b) Hitung,

*Calculate,*

- i. varians

*Variance,*

- ii. sisihan piawai

*standard deviation*

Berikan jawapan anda betul kepada empat tempat perpuluhan.

*Give your answer correct to 4 decimal places.*

[5 markah/ marks]

Jawapan / Answer:

Untuk  
Kegunaan  
Pemeriksa

(a)

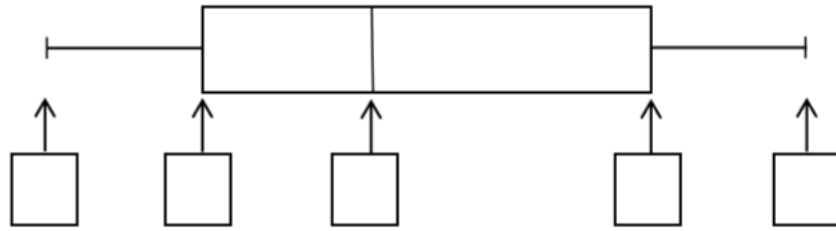

(b) (i)

(ii)

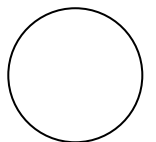

- 14 (a) Rajah 5.1 merupakan pelan dan pandangan hadapan sebuah prisma.

*The diagram 5.1 is a plan and front view of prism.*

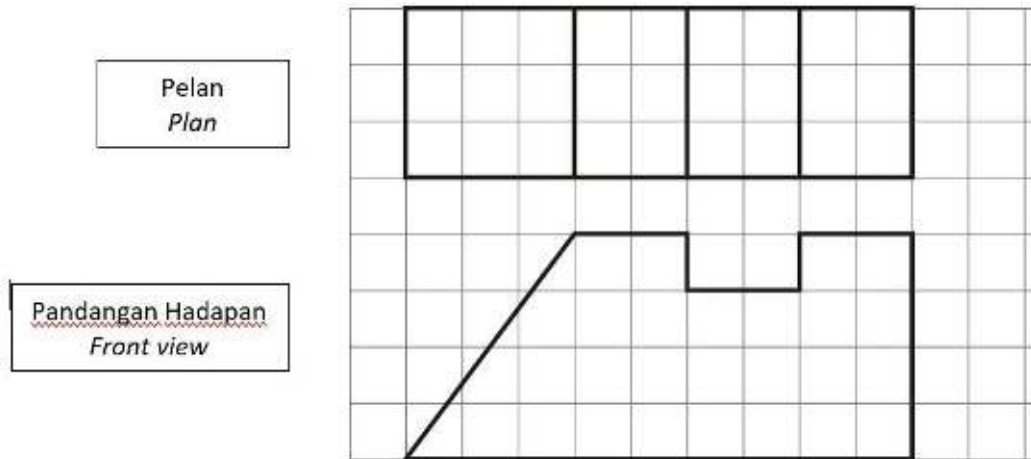

Rajah / Diagram 5.1

Lukiskan pandangan sisi prisma berkenaan pada ruangan grid yang telah disediakan.

*Draw a side view, in the space provided.*

[2 markah/ marks]

- (b) Sebuah pepejal berbentuk separuh silinder berdiameter 6 cm dicantumkan kepada prisma pada rajah 5.2 pada satah SLKT . Panjang SK ialah 4 cm. Gabungan pepejal adalah seperti ditunjukkan pada Rajah 5.2.

*A semi - cylindrical solid with a diameter of 6 cm is attached to the prism in figure 5.2 on the SLKT plane. The length of the SK is 4 cm. The Solid combination is as shown in figure 5.2*

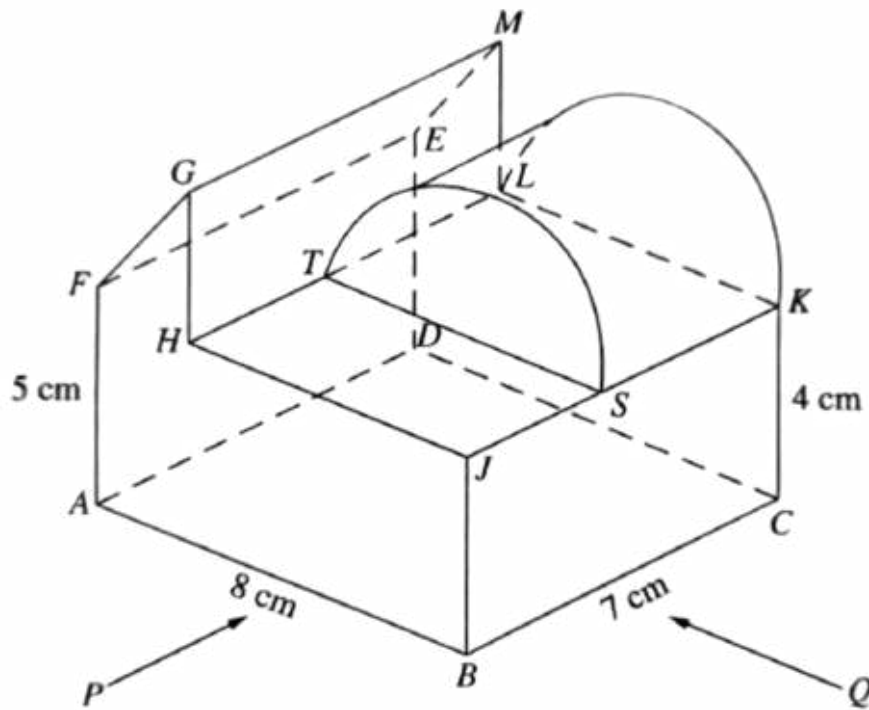

Rajah / Diagram 5.2

Lukis dengan skala penuh ,

*Draw at full scale,*

- (i) Pelan gabungan pepejal itu,

*Plan the solid combination,*

[3 markah/ marks]

- (ii) Dongakan gabungan pepejal itu pada satah mencancang yang selari dengan AB sebagaimana dilihat dari P.

*Elavate the combined solid on a vertical plane intersecting with AB as seen from P.*

[4 markah/ marks]

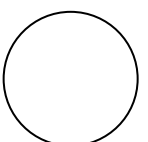

Untuk  
Kegunaan  
Pemeriksa

Jawapan / Answer:

(a)

Sisi

Pandangan Sisi  
Side view

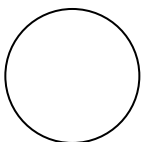
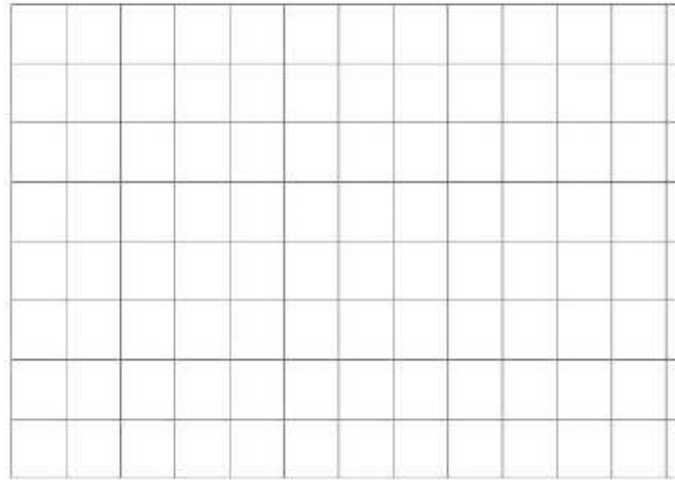

(b) (i), (ii)

*Untuk  
Kegunaan  
Pemeriksa*

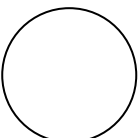
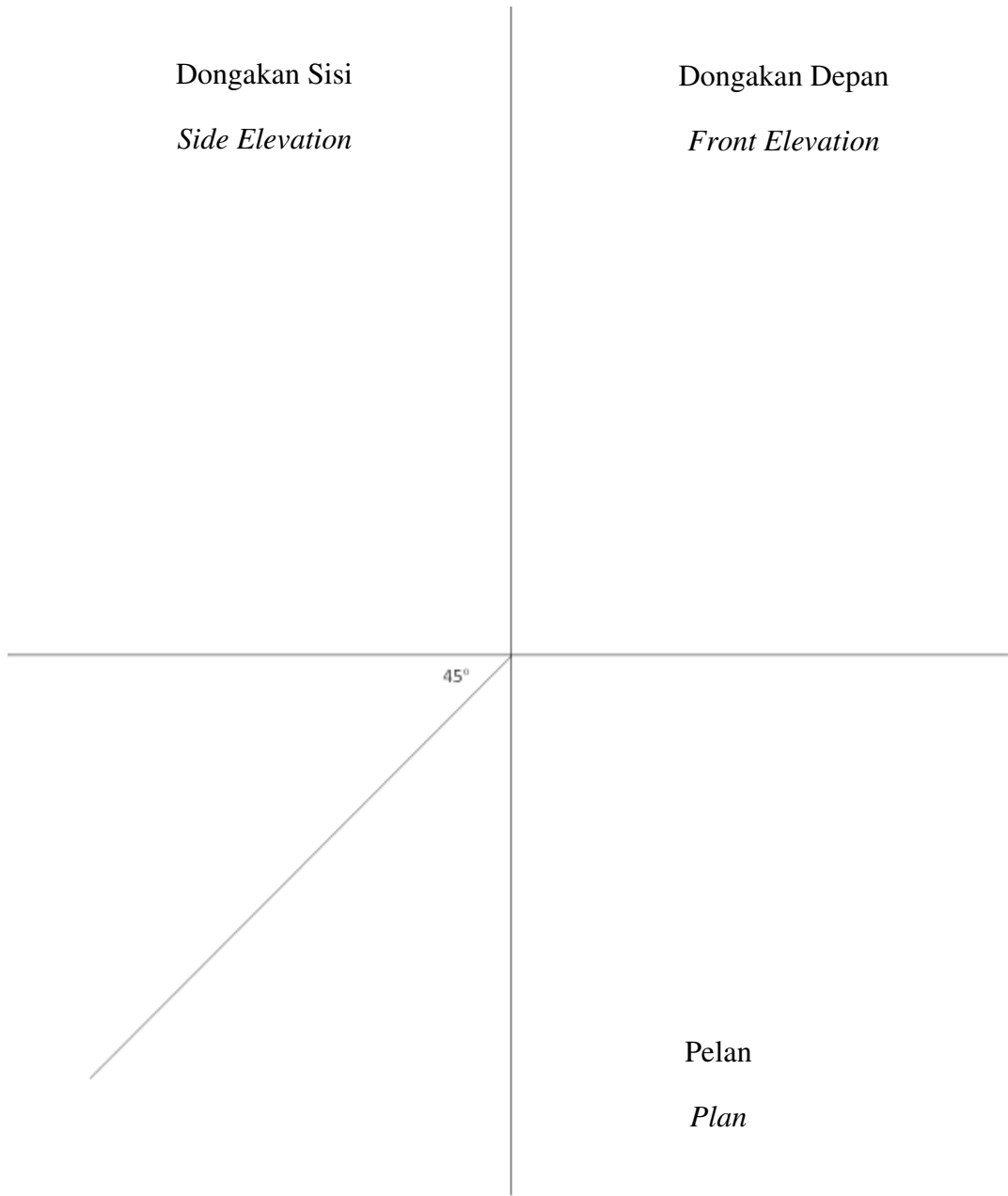

- 15 (a) Rajah 6.1 menunjukkan dua polygon ABCD dan A' B' C' D' yang dilukis pada grid segi empat sama bersisi 1 unit. Pada rajah itu, A' B' C' D' ialah imej bagi ABCD di bawah suatu pantulan tertentu.

*Diagram 6.1 shows two polygons ABCD and A' B' C' D' drawn on a grid of square with sides of 1 unit. On the diagram, A' B' C' D' is the image of ABCD under a reflection.*

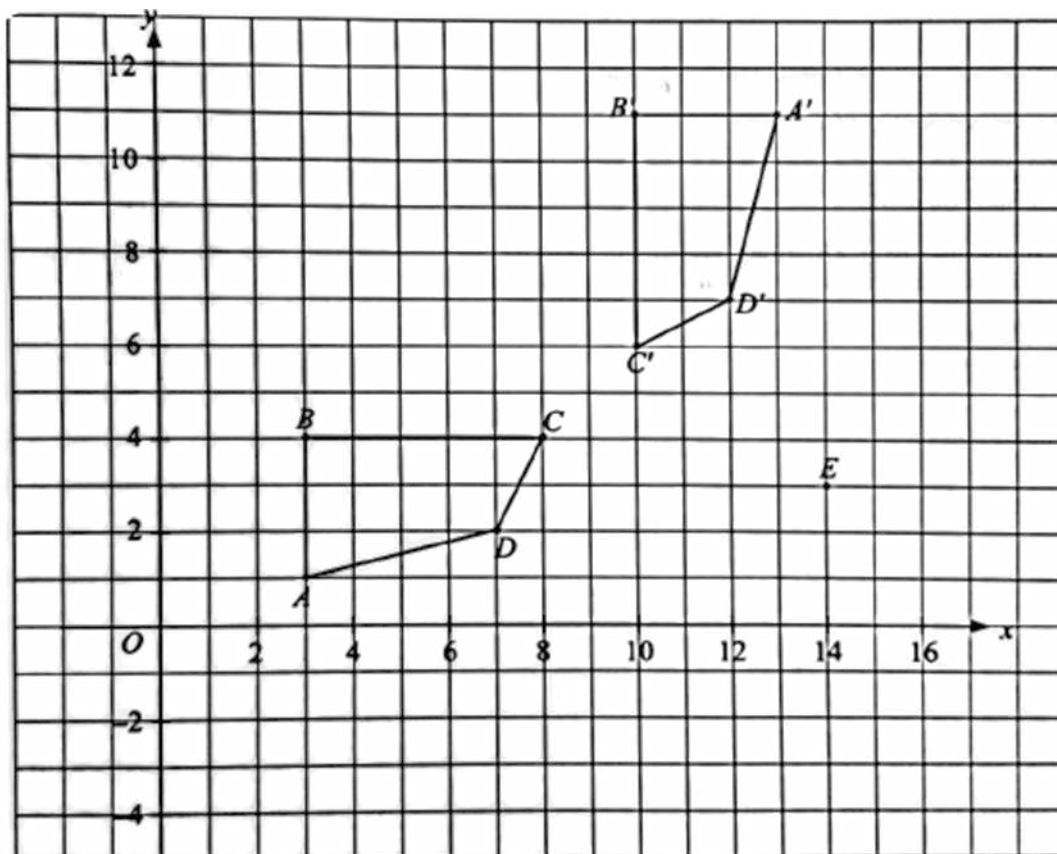

Rajah / Diagram 6.1

Pada ruangan jawapan,

*On the answer space,*

- (i) Lukis paksi pantulan itu.

*Draw the axis of reflection.*

[1 markah/ marks]

- (ii) E' ialah imej bagi titik E di bawah pantulan yang sama. Plotkan titik E'.

*E' is the image of point E under the same reflection. Plot the point E'.*

[1 markah/ marks]

- (iii) Lukis imej ABCD di bawah pantulan pada paksi-x.

*Draw the image of ABCD under reflection in the x-axis.*

[2 markah/ marks]

- (b) Rajah 6.2 menunjukkan dua pentagon PQRST dan JKLMN dilukis pada suatu satah Cartesan

*Diagram 6.2 shows two pentagons PQRST and JKLMN drawn on a Cartesian plane.*

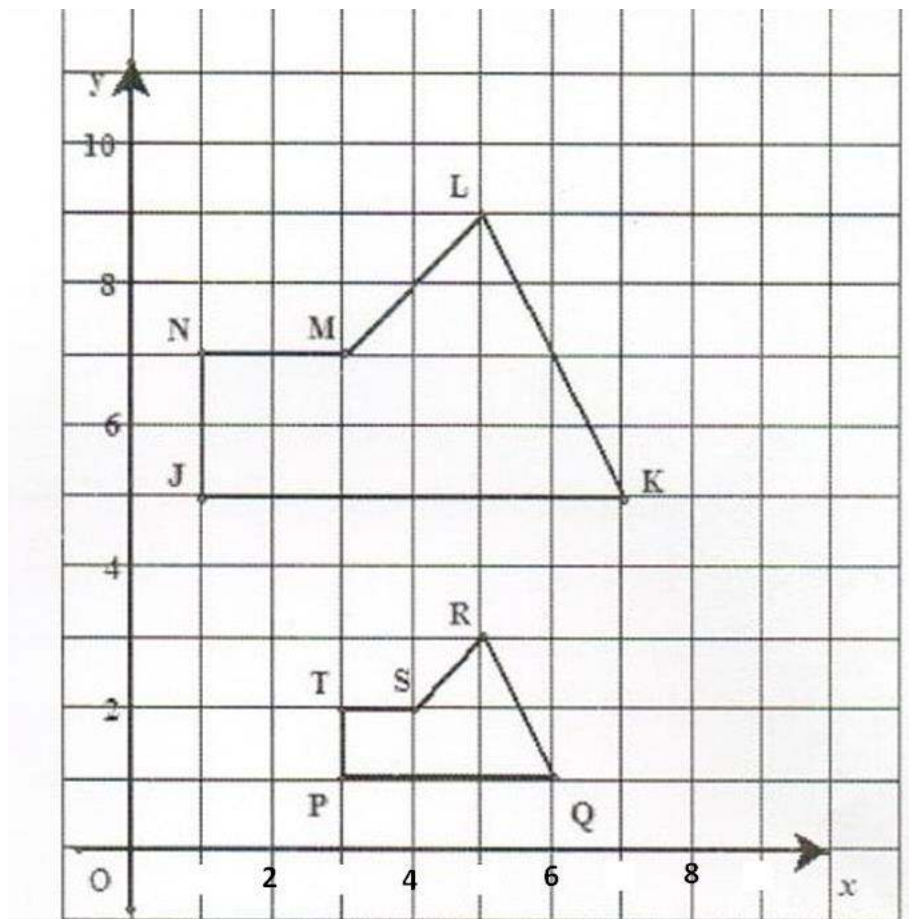

*Rajah / Diagram 6.2*

JKLMN ialah imej bagi PQRST di bawah gabungan penjelmaan WV. Huraikan selengkapnya penjelmaan.

*JKLMN is the image of PQRST under the combined transformation WV. Describe, in full, transformation.*

- (i) V  
(ii) W

[5 markah/ marks]

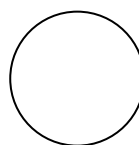



Untuk  
Kegunaan  
Pemeriksa

Jawapan / Answer:

(a)

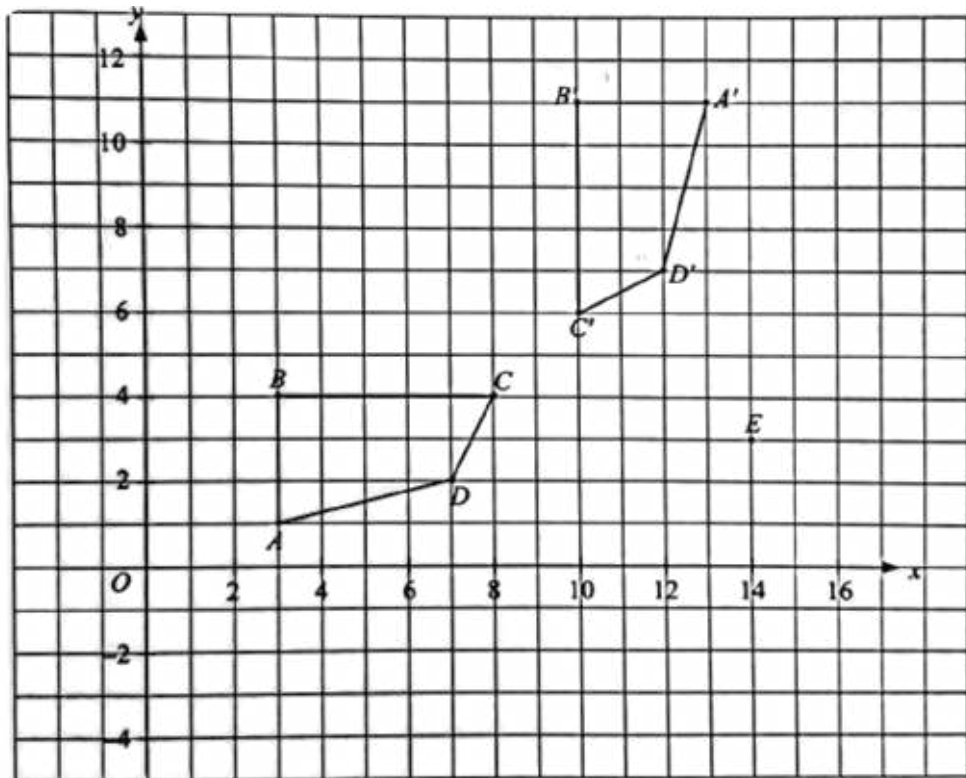

(b) (i)

(ii)

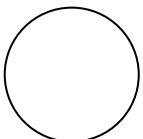

**Bahagian/Section C**  
**[15 markah/marks]**

Jawab **satu** soalan sahaja dalam bahagian ini.  
*Choose **one** question only from this section.*

- 16 Syarikat Aman telah berjaya menjual 100 buah kereta dalam tempoh 3 bulan. Harga jualan bagi kereta model X dan model Y masing- masing dijual dengan harga RM 35 000 dan RM 65 000. Jumlah harga jualan kereta tersebut adalah sebanyak RM 4 400 000 . Berapakah unit kereta model X dan Y yang telah dijual oleh syarikat Aman?

*Syarikat Aman has managed to sell 100 cars within 3 months. The selling price for model X and model Y cars is RM 35 000 and RM 65 000 respectively. The amount for the sale of the car is RM 4 400 000. How many car units for X and Y models that have been sold by Syarikat Aman?*



**Model X**  
*Model X*



**Model Y**  
*Model Y*

Rajah / Diagram 7.1

- (a) (i) Tuliskan persamaan linear serentak berikut dalam bentuk persamaan matriks:

*Write the following simultaneous linear equations as a matrix equation:*

[1 markah/ marks]

- (ii) Seterusnya, menggunakan kaedah matriks, hitung nilai X dan nilai Y.

*Hence, using matrix method, calculate the values of X and Y.*

[4 markah/ marks]

- (iii) Rajah 7.2 menunjukkan piktograf bagi jualan kereta model X dan Y. Jualan pada bulan Mac tidak ditunjukkan. Lengkapkan piktogram di bawah.

*Diagram 7.2 is shows the pictograph of sales of car for model X and Y. The sales in March is not shown. Complete pictogram below.*

[2 markah/ marks]

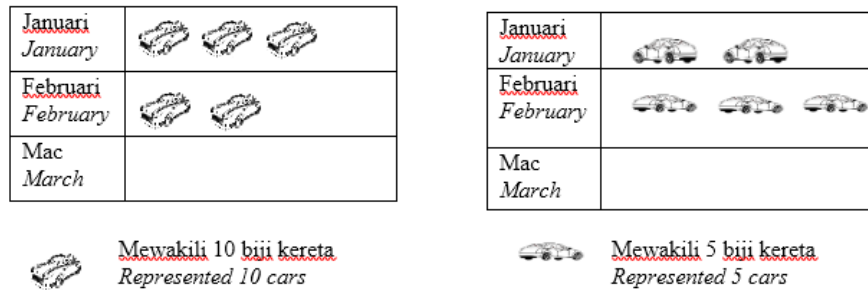

Rajah / Diagram 7.2

- (b) Farha ingin membeli sebuah kereta model X dari Syarikat Aman. Beliau ingin membuat pinjaman bank bagi membeli kereta berkenaan.

*Farha wants to buy a X model car from Syarikat Aman. She wants to take out a bank loan to buy the car.*

- (i) Berapakah jumlah pinjaman bank yang akan dibuat jika kadar faedah tahunan sebanyak 4% dengan tempoh bayaran balik selama 9 tahun.

*What is the amount of bank loan that will be made if the annual interest rate is 4% with a repayment period of 9 years?*

[3 markah/ marks]

- (ii) Berapakah ansuran bulanan yang perlu dibayar oleh Farha?

*How much monthly installment does Farha have to pay?*

[2 markah/ marks]

- (c) Syarikat Aman telah memberi diskaun sebanyak 25% untuk kereta model Y. Berapakah harga kereta tersebut selepas potongan diskaun dalam asas lapan.

*Syarikat Aman has given a discount of 25% for model Y cars. What is the price of the car after the discount deduction in base eight.*



[3 markah/ marks]

Jawapan / Answer:

(a) (i)



(ii)

(iii)

|                             |   |
|-----------------------------|---|
| Januari<br><i>January</i>   |  |
| Februari<br><i>February</i> |  |
| Mac<br><i>March</i>         |   |



Mewakili 10 biji kereta  
*Represented 10 cars*

|                             |   |
|-----------------------------|---|
| Januari<br><i>January</i>   |  |
| Februari<br><i>February</i> |  |
| Mac<br><i>March</i>         |   |



Mewakili 5 biji kereta  
*Represented 5 cars*

Untuk  
Kegunaan  
Pemeriksa

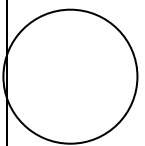

*Untuk  
Kegunaan  
Pemeriksa*

(b) (i)

(ii)

(c)

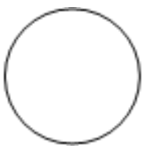

- 17 (a) Johan menjual nasi lemak dan nasi goreng di Medan Selera Pekan. Harga sepinggan nasi lemak ialah RM3 dan harga sepinggan mi goreng ialah RM4. Johan menjual  $x$  pinggan nasi lemak dan  $y$  pinggan mi goreng sehari. Syarat-syarat bagi jualan makanan adalah seperti dalam Rajah 8.1 :

*Johan sells nasi lemak and fried rice in Pekan Food Court. The price of a plate of nasi lemak is RM3 and the price of a plate of fried noodles is RM4. Johan sells  $x$  plates of nasi lemak and  $y$  plates of fried noodles in a day. The conditions of the food sales are as Diagram 8.1 :*

| Nasi Lemak   | Mi goreng/ <i>fried noodles</i>   |
|--|---|
|    |  |
| <p>I. Jualan kedua-dua nasi tidak lebih daripada 150 pinggan.<br/><i>The sales of both rice are not more than 150 plates.</i></p> <p>II. Jumlah pendapatan daripada jualan tidak kurang daripada RM480.<br/><i>The total income from the sales is not less than RM480.</i></p> |   |

Rajah / *Diagram 8.1*

- (i) Senaraikan semua ketaksamaan linear selain daripada  $x \geq 0$  dan  $y \geq 0$  yang mewakili jualan makanan.

*List all the linear inequalities other than  $x \geq 0$  and  $y \geq 0$  which represent the food sales.*

[2 markah/ marks]

- (ii) Lukis dan lorek rantau sepunya yang memuaskan sistem ketaksamaan linear tersebut pada ruangan jawapan yang diberi.

*Draw and shade the common region which satisfies the system of linear inequalities.*

[3 markah / marks]

- (b) Johan menunggang motosikal ke Medan Selera Pekan setiap pagi. Rajah 8.2 di bawah menunjukkan graf laju-masa bagi pergerakan motosikal Johan dari rumah ke persimpangan lampu isyarat sebelum sampai ke medan selera itu.

*Johan rides a motorcycle to the Johan Food Court Pekan every morning. Diagram 8.2 shows a speed-time graph for Johan's motorcycle movement from his house to the traffic light junction before he reach at the food court.*

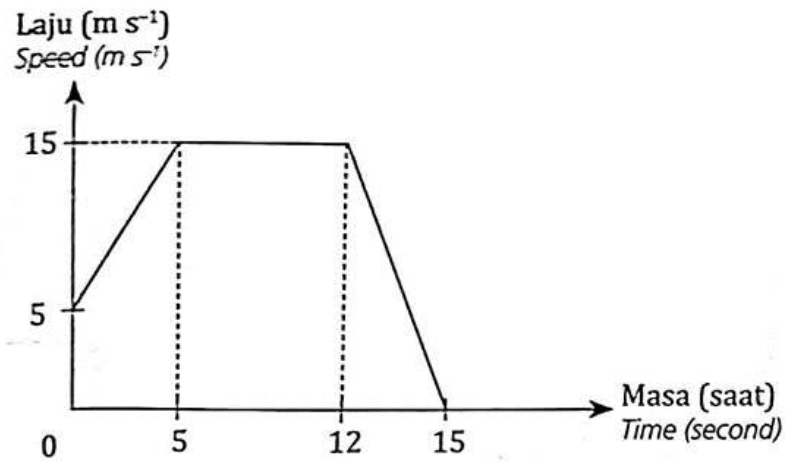

Rajah / Diagram 8.2

- (i) Huraikan gerakan motosikal Johan untuk tempoh 5 saat pertama.

*Describe Johan's motorcycle movement for the period of the first 5 seconds.*

[1 markah / marks]

- (ii) Apakah yang berlaku terhadap gerakan motorsikal Johan dari saat ke-5 hingga saat ke-12?

*What is happen to Johan's motorcycle movement from 5th seconds to 12th seconds?*

[1 markah / marks]

- (iii) Hitung kadar perubahan laju terhadap masa, dalam  $ms^{-2}$ , bagi 3 saat terakhir.

*Calculate the rate of change of speed to time, in  $ms^{-2}$ , for the last 3 seconds.*

[2 markah / marks]

- (iv) Hitung jarak, dalam  $m$ , yang dilalui semasa nyahpecutan dan huraikan gerakan motosikal pada tempoh tersebut.

*Calculate the distance, in  $m$ , travelled during deceleration and describe the motorcycle movement in the period.*

[3 markah / marks]

- (c) Jadual 5.1 menunjukkan jumlah hasil jualan makanan, dalam RM, bagi Johan dalam 20 hari.

*Table 5.1 below shows the total of food sales, in RM, of Johan in 20 days.*

|     |     |     |     |     |
|-----|-----|-----|-----|-----|
| 502 | 503 | 507 | 555 | 608 |
| 551 | 508 | 609 | 607 | 652 |
| 552 | 651 | 552 | 553 | 559 |
| 602 | 705 | 604 | 558 | 608 |

*Jadual / Table 5.1*

Wakilkan jumlah hasil jualan makanan tersebut dalam sebuah plot batang-dan-daun.

*Represent the total of food sales in a stem-and-leaf plot.*

[3 markah/ marks]



*Untuk  
Kegunaan  
Pemeriksa*

Jawapan / Answer :

(a) (i)

(ii)

|  |  |  |  |  |  |  |  |  |  |  |  |  |  |  |  |  |  |  |  |  |  |
|--|--|--|--|--|--|--|--|--|--|--|--|--|--|--|--|--|--|--|--|--|--|
|  |  |  |  |  |  |  |  |  |  |  |  |  |  |  |  |  |  |  |  |  |  |
|  |  |  |  |  |  |  |  |  |  |  |  |  |  |  |  |  |  |  |  |  |  |
|  |  |  |  |  |  |  |  |  |  |  |  |  |  |  |  |  |  |  |  |  |  |
|  |  |  |  |  |  |  |  |  |  |  |  |  |  |  |  |  |  |  |  |  |  |
|  |  |  |  |  |  |  |  |  |  |  |  |  |  |  |  |  |  |  |  |  |  |
|  |  |  |  |  |  |  |  |  |  |  |  |  |  |  |  |  |  |  |  |  |  |
|  |  |  |  |  |  |  |  |  |  |  |  |  |  |  |  |  |  |  |  |  |  |
|  |  |  |  |  |  |  |  |  |  |  |  |  |  |  |  |  |  |  |  |  |  |
|  |  |  |  |  |  |  |  |  |  |  |  |  |  |  |  |  |  |  |  |  |  |
|  |  |  |  |  |  |  |  |  |  |  |  |  |  |  |  |  |  |  |  |  |  |
|  |  |  |  |  |  |  |  |  |  |  |  |  |  |  |  |  |  |  |  |  |  |
|  |  |  |  |  |  |  |  |  |  |  |  |  |  |  |  |  |  |  |  |  |  |

(b) (i)

(ii)

(iii)

(iv)

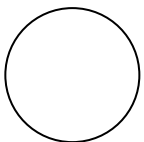

(c)

*Untuk  
Kegunaan  
Pemeriksa*

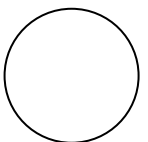

**MAKLUMAT UNTUK CALON**  
**INFORMATION FOR CANDIDATES**

- 1 Kertas soalan ini mengandungi tiga bahagian: **Bahagian A, Bahagian B** dan **Bahagian C**.

*This question paper consist of three sections: **Section A, Section B and Section C**.*

- 2 Jawab **semua** soalan dalam **Bahagian A and B** dan mana-mana **satu** soalan daripada Bahagian C.

*Answer **all** questions in **Section A and B** and any **one** questions from **Section C**.*

- 3 Tulis jawapan anda pada ruang yang disediakan dalam kertas soalan ini.

*Write your answers in the spaces provided in the question paper.*

- 4 Tunjukkan kerja mengira anda. Ini boleh membantu anda untuk mendapatkan markah.

*Show your working. It may help you to get marks.*

- 5 Jika anda hendak menukar jawapan, batalkan jawapan yang telah dibuat. Kemudian tulis jawapan yang baru.

*If you wish to change your answer, cross out the answer that you have done. Then write down the new answer.*

- 6 Rajah yang mengiringi soalan tidak dilukis mengikut skala kecuali dinyatakan.

*The diagrams in the questions provided are not drawn to scale unless stated.*

- 7 Markah diperuntukkan bagi setiap soalan dan ceraian soalan ditunjukkan dalam kurungan.

*The marks allocated for each question and sub-part of a question are shown in brackets.*

- 8 Satu senarai rumus disediakan di halaman 2 dan 3

*A list of formulae is provided on pages 2 and 3.*

- 9 Anda dibenarkan menggunakan kalkulator saintifik.

*You may use a scientific calculator.*

- 10 Serahkan kertas soalan ini kepada pengawas peperiksaan pada akhir peperiksaan.

*Hand in this question paper to the invigilator at the end of the examination.*

PPC MATEMATIK 2021

SKEMA JAWAPAN

KERTAS 1

SET 1

| No Soalan | Jawapan |
|-----------|---------|
| 1         | B       |
| 2         | C       |
| 3         | D       |
| 4         | C       |
| 5         | A       |
| 6         | B       |
| 7         | D       |
| 8         | D       |
| 9         | A       |
| 10        | C       |

| No Soalan | Jawapan |
|-----------|---------|
| 21        | C       |
| 22        | B       |
| 23        | A       |
| 24        | D       |
| 25        | A       |
| 26        | B       |
| 27        | A       |
| 28        | D       |
| 29        | B       |
| 30        | C       |

| No Soalan | Jawapan |
|-----------|---------|
| 11        | B       |
| 12        | A       |
| 13        | B       |
| 14        | C       |
| 15        | A       |
| 16        | C       |
| 17        | B       |
| 18        | D       |
| 19        | A       |
| 20        | A       |

| No Soalan | Jawapan |
|-----------|---------|
| 31        | B       |
| 32        | A       |
| 33        | D       |
| 34        | C       |
| 35        | B       |
| 36        | D       |
| 37        | D       |
| 38        | C       |
| 39        | C       |
| 40        | D       |

Peraturan  
Pemarkahan  
Matematik  
Kertas 2  
November  
2021

**SKEMA**

**PEPERIKSAAN PERCUBAAN SPM  
TINGKATAN 5 2021  
DAERAH PEKAN**

---

**MATHEMATICS  
KERTAS 2  
SET 1**

**PERATURAN PEMARKAHAN**

---

UNTUK KEGUNAAN GURU SAHAJA

| Question | Solution and Mark Scheme   | Sub Mark               | Mark |
|----------|--|------------------------|------|
| 1. (a)   | $P = kj^2$ $k = \frac{P}{j^2}$ $k = \frac{1\,250}{25^2}$ $k = 2$   | P1<br><br>K1<br><br>N1 | 3    |
| 2. (a)   | Mencari tempoh simpanan yang diperlukan supaya simpanan Jaya menjadi RM14,500 daripada nilai asal RM13,500   | P1                     | 3    |
| (b)      | Kadar faedah tidak berubah sepanjang tempoh simpanan diperlukan<br>- Harga jualan motorsikal tidak berubah sepanjang tempoh simpanan<br>(mana-mana satu jawapan) | P1                     |      |
| (c)      | Faedah/Modal simpanan (Prinsipal)/ kadar faedah /Tempoh simpanan<br>(Tahun)<br>(mana-mana satu jawapan)  | P1                     |      |
| 3. (a)   | $\frac{22}{7} \times 15^2 \times 13$ $9192.86$   | K1<br><br>N1           | 4    |
| (b)      | $9192.86 - 5798.57 \quad \text{OR} \quad \frac{4}{73} \times \frac{22}{7} \times 3^3$ $\frac{3394.29}{113.14}$ $30$  | K1<br><br>K1<br><br>N1 |      |

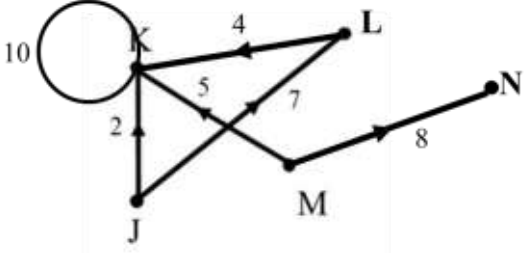
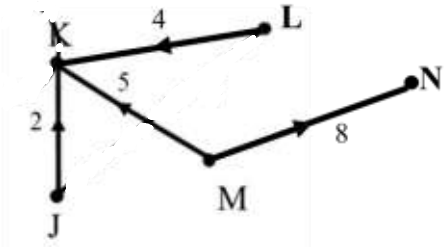
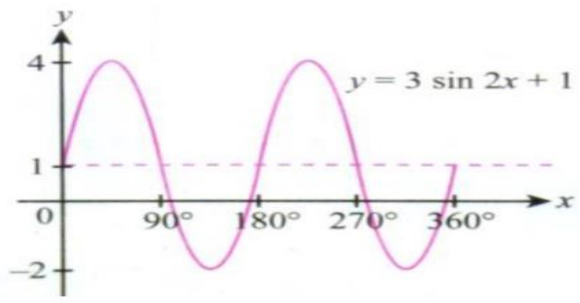
|               |  |   |          |
|---------------|--|---|----------|
| <p>4.</p>     | <p><math>x = \text{epal hijau}, y = \text{epal merah}</math></p> <p><math>x + y = 100 \quad \text{OR} \quad 0.80x + 1.20y = 108</math></p> $\begin{bmatrix} 1 & 1 \\ 0.80 & 1.20 \end{bmatrix} \begin{bmatrix} x \\ y \end{bmatrix} = \begin{bmatrix} 100 \\ 108 \end{bmatrix}$ $\begin{bmatrix} x \\ y \end{bmatrix} = \frac{1}{1(1.20) - 1(0.80)} \begin{bmatrix} 1.20 & -1 \\ -0.80 & 1 \end{bmatrix} \begin{bmatrix} 100 \\ 108 \end{bmatrix}$ $\begin{bmatrix} x \\ y \end{bmatrix} = -\frac{1}{0.4} \begin{bmatrix} 1.20 & -1 \\ -0.80 & 1 \end{bmatrix} \begin{bmatrix} -100 \\ -80 \end{bmatrix}$ <p><math>x = 30 \text{ epal hijau}</math><br/><math>y = 70 \text{ epal merah}</math></p> | <p>P1</p> <p>P1</p> <p>K1</p> <p>N1</p> <p>N1</p> | <p>5</p> |
| <p>5. (a)</p> |    | <p>P2</p>   |          |
| <p>(b)</p>    |   | <p>P2</p>   | <p>4</p> |
| <p>6.</p>     |  <p>Paksi-x betul dan seragam<br/>Paksi-y betul dan seragam<br/>Titi diplot dengan betul<br/>Graf lenkung licin</p>   | <p>P1</p> <p>P1</p> <p>K1</p> <p>N1</p>           | <p>4</p> |

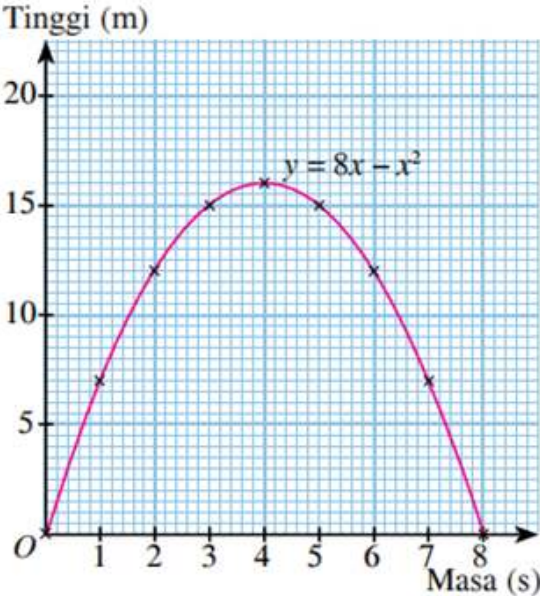
|         |  |                        |   |
|---------|--|------------------------|---|
| 7. (a)  | 75% x RM500 000<br><br>RM375 000   | K1<br><br>N1           |   |
| (b)     | Encik Halim akan menerima bayaran pampasan maksimum sebanyak RM375 000 iaitu nilai muka insuran yang dibelinya.  | K1N1                   | 4 |
| 8.      | $\frac{270}{360} \times \frac{22}{7} \times 9^2 \text{ OR } \frac{1}{2} \times 4 \times 6$ $\left(\frac{270}{360} \times \frac{22}{7} \times 9^2\right) - \left(\frac{1}{2} \times 4 \times 6\right)$ $178 \frac{13}{14} \text{ or } \frac{2505}{14} \text{ or } 178.93$ | K1<br><br>K1<br><br>N1 | 3 |
| 9.      |  <p>paksi dan skala betul.<br/>plot titik dengan betul.<br/>lukis lengkung dengan licin.</p>   | P1<br>K1<br>K1<br>N1   | 4 |
| 10. (a) | <p>{(P,2) (P,0) (P,2) (P,1) (E,2) (E,0) (E,2) (E,1) (K,2) (K,0) (K,2) (K,1) (A,2) (A,0) (A,2) (A,1) (N,2) (N,0) (N,2) (N,1)}</p> <p>Nota : Beri P1 untuk mana-mana 2 kesalahan.</p>  | P2                     |   |

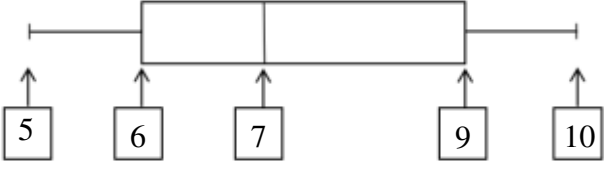

|         |   |  |        |
|---------|---|--|--------|
| (b)     | <p>{(P,1) (K,1) (N,1)}</p> $\frac{3}{20}$   | K1   |        |
| 11. (a) | <p>Simpanan tetap bulanan = RM420</p> <hr/> <p>Baki pendapatan = RM3530</p> <hr/> <p>Perbelanjaan tetap bulanan</p> <p>Insurans peribadi = RM85<br/>         Bayaran pinjaman kenderaan = RM550<br/>         Sewa rumah = RM600<br/>         Yuran bulanan gymnasium = RM70<br/>         * beri K1 sekurang-kurang 3 betul</p> <hr/> <p>Jumlah perbelanjaan tetap bulanan = RM 1305</p> <hr/> <p>Perbelanjaan tidak tetap bulanan</p> <p>Makanan = RM1050<br/>         Bil air, elektrik dan telefon = RM270<br/>         Gas dan petrol = RM120<br/>         Percutian = RM520<br/>         * beri K1 sekurang-kurang 3 betul</p> <hr/> <p>Jumlah perbelanjaan tidak tetap bulanan = RM 1960</p> <hr/> <p>Pendapatan lebihan = RM265</p> <hr/> <p>(b) <math>\frac{RM1700}{6} = RM283.33</math></p> <hr/> <p>Encik Azman dapat membeli mesin pengering pakaian dalam tempoh yang dikehendaki (kerana kos mesin kurang daripada jumlah simpanan tetap bulanan Encik Azman)</p> | N1<br>N1<br>K1<br>N1<br>K1<br>N1<br>N1<br>K1<br>N1 | 4<br>9 |
| 12. (a) | i. Tan<br>ii. Sabri   | P1<br>P1   |        |
| (b)     | 20 km   | P1   |        |
| (c)     | $\frac{40}{\left(\frac{90}{60}\right)}$ <p>26.67 @ 26 <math>\frac{2}{3}</math> jam</p>  | K1<br>N1   |        |

|         |  |   |                |
|---------|--|---|----------------|
| (d)     | <p>i. 10 minit</p> <p>ii. <math>32 = \frac{40}{\text{masa}}</math></p> <p>Masa = 75 minit</p> <p>Nota : Beri K1 untuk 1.25 jam dilihat</p>   | <p>P1</p> <p>K1</p> <p>N2</p>                     | <hr/> <p>9</p> |
| 13. (a) | <p>Julat = 5</p> <p><math>Q_1 = 6</math> OR <math>Q_3 = 9</math></p> <p>Julat antara kuartil = 3</p>  <p>Nota : Beri N1 untuk median = 7 <b>OR</b> minimum = 5 dan maksimum = 10</p> | <p>P1</p> <p>P1</p> <p>P1</p> <p>P1</p> <p>P1</p> |                |
| (b)     | <p><math>\text{min} = \frac{206}{28}</math></p> <p>= 7.3571</p> <p>Varians ;</p> <p><math>= \frac{1570}{28} - (7.3571)^2</math></p> <p>= 1.9439</p> <p>Sisihan piawai ;</p> <p>= 1.3942</p>  | <p>K1</p> <p>K1</p> <p>N1</p> <p>N1</p>           | <p>9</p>       |

14. (a)

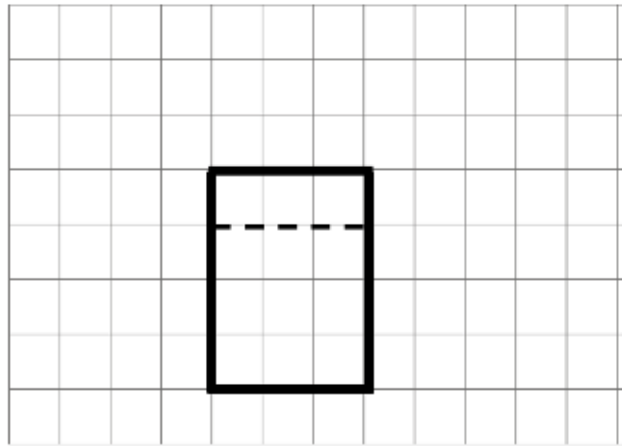

- i. Bentuk dan garis putus-putus dengan ukuran yang betul.
- ii. Bentuk segi empat dengan ukuran yang betul.
- iii. Garis putus-putus dengan ukuran yang betul kelihatan

(i)

(b)

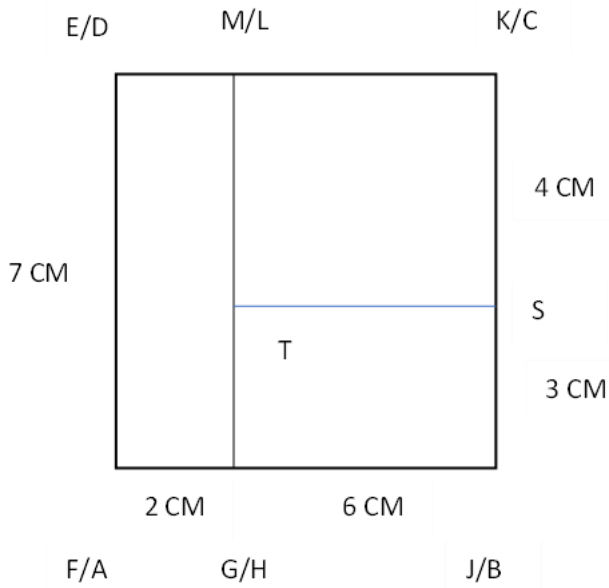

Bentuk yang betul dengan segi empat tepat EMGF, TSJH dan LKST.

$$EM = FG, TS = JH, LK = TS$$

Ukuran adalah betul kepada  $\pm 0.2$  cm (sehala) dan sudut pada semua bucu segi empat tepat ialah  $90^\circ \pm 1^\circ$

P2  
P1  
P1

K1  
K1  
N1

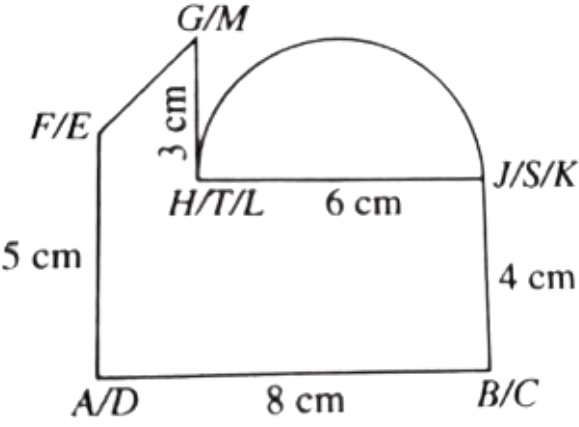
|         |   |                            |   |
|---------|---|----------------------------|---|
|         | <p>ii.</p>  <p>Bentuk yang betul dengan FGHIJA dan semi bulatan TS<br/> <math>AB &gt; HJ = FA &gt; JB = JB &gt; GH</math></p> <p>Ukuran adalah betul kepada <math>\pm 0.2</math> cm ( satu arah) dan sudut pada semua bucu segi empat tepat ialah <math>90^\circ \pm 1^\circ</math></p>  | K1<br>K1<br>N2             | 9 |
| 15. (a) | <p>i. Garisan paksi pantulan dilukis dengan betul.</p> <p>ii. Imej bagi titik E (11, 0) di plotkan dengan betul.</p> <p>iii. Bentuk dan saiz serta membuat pantulan yang betul.</p>   | P1<br>P1<br>P2             |   |
| (b)     | <p>i. <math>V =</math> Translasi <math>\begin{pmatrix} -2 \\ 4 \end{pmatrix}</math> atau Translasi <math>\begin{pmatrix} 1 \\ 4 \end{pmatrix}</math></p> <p>ii. <math>W =</math> Pembesaran, faktor skala = 2, pusat pembesaran = K (7,5) atau J(1,5).</p>  | P2<br>P3                   | 9 |
| 16. (a) | <p><math>x + y = 100</math> or <math>35\,000x + 65\,000y = 4\,400\,000</math></p> $\begin{pmatrix} 1 & 1 \\ 35\,000 & 65\,000 \end{pmatrix} \begin{pmatrix} x \\ y \end{pmatrix} = \begin{pmatrix} 100 \\ 4\,400\,000 \end{pmatrix}$ $\begin{pmatrix} x \\ y \end{pmatrix} = \frac{1}{(1)(65\,000) - (1)(35\,000)} \begin{pmatrix} 1 & 1 \\ 35\,000 & 65\,000 \end{pmatrix} \begin{pmatrix} 100 \\ 4\,400\,000 \end{pmatrix}$ <p><math>x = 70</math></p> <p><math>y = 30</math></p> | P1<br>P1<br>K1<br>N1<br>N1 |   |

|  |  |                     |
|--|--|---------------------|
| <p>(b)</p> <p>i. <math>35000 + (35000 \times 4\% \times 9)</math></p> <p>RM 47600</p> <p>Nota : Beri 1 markah jika <math>(35000 \times 4\% \times 9)</math> ditunjukkan.</p> <p>ii. <math>RM\ 47600 \times (9 \times 12)</math></p> <p>RM 440.74</p> <p>(c)</p> <p><math>RM\ 65000 \times 75\%</math></p> <p>RM 48750</p> <p><math>RM\ 48750_{10} = RM\ 137156_8</math></p> <p>Nota : Beri 1 markah jika <math>RM65000 - (65000 \times 25\%)</math> ditunjukkan.</p> | <p>K1K1</p> <p>N1</p> <p>K1</p> <p>N1</p> <p>K1</p> <p>K1</p> <p>N1</p>  | <p>15</p>           |
| <p>17. (a)</p> <p>i. <math>x + y \leq 150</math></p> <p><math>3x + 4y \geq 480</math></p> <p>ii.</p> <div data-bbox="427 1137 887 1527" data-label="Figure"> </div> <p>Garis lurus <math>y = -x + 150</math> dilukis,</p> <p>Garis lurus <math>y = -\frac{3}{4}x + 120</math> dilukis</p> <p>Rantau yang memenuhi ketaksamaan dilorek</p>  | <p>P1</p> <p>P1</p> <p>K1</p> <p>K1</p> <p>K1</p>  | <p>P1</p> <p>P1</p> |
| <p>(b)</p>   | <p>i. Motosikal mengalami pecutan dengan kadar <math>2\ ms^{-2}</math> dalam tempoh 5 saat.</p> <p>ii. Motosikal Ahmad bergerak dengan laju seragam <math>15\ ms^{-1}</math> dari saat ke-5 hingga saat ke-12.</p> | <p>P1</p> <p>P1</p> |

|        | iii. Kadar perubahan laju = $\frac{0-15}{15-12}$<br>$= -5ms^{-2}$   | K1     |    |      |    |         |    |               |    |             |    |     |    |
|--------|---|--------|----|------|----|---------|----|---------------|----|-------------|----|-----|----|
|        |   | N1     |    |      |    |         |    |               |    |             |    |     |    |
|        | iv. Jarak = $\frac{1}{2} \times 3 \times 15$<br>$= 22.5 \text{ m}$  | K1     |    |      |    |         |    |               |    |             |    |     |    |
|        |   | N1     |    |      |    |         |    |               |    |             |    |     |    |
| (c)    | Motosikal bergerak sejauh 22.5 m dalam tempoh 3 saat dengan<br>nyahpecutan $5ms^{-2}$ .   | N1     |    |      |    |         |    |               |    |             |    |     |    |
|        | <table style="width: 100%; border-collapse: collapse;"> <thead> <tr> <th style="width: 30%;">Batang</th> <th style="width: 70%;">Daun</th> </tr> </thead> <tbody> <tr> <td>50</td> <td>2 3 7 8</td> </tr> <tr> <td>55</td> <td>1 2 2 3 5 8 9</td> </tr> <tr> <td>60</td> <td>2 4 7 8 8 9</td> </tr> <tr> <td>65</td> <td>1 2</td> </tr> <tr> <td>70</td> <td>5</td> </tr> </tbody> </table> | Batang |    | Daun | 50 | 2 3 7 8 | 55 | 1 2 2 3 5 8 9 | 60 | 2 4 7 8 8 9 | 65 | 1 2 | 70 |
| Batang | Daun  |        |    |      |    |         |    |               |    |             |    |     |    |
| 50     | 2 3 7 8   |        |    |      |    |         |    |               |    |             |    |     |    |
| 55     | 1 2 2 3 5 8 9   |        |    |      |    |         |    |               |    |             |    |     |    |
| 60     | 2 4 7 8 8 9   |        |    |      |    |         |    |               |    |             |    |     |    |
| 65     | 1 2   |        |    |      |    |         |    |               |    |             |    |     |    |
| 70     | 5   |        |    |      |    |         |    |               |    |             |    |     |    |
|        | Kekunci 50   2 bermaksud RM 502   |        |    |      |    |         |    |               |    |             |    |     |    |
|        |   |        | 15 |      |    |         |    |               |    |             |    |     |    |